

High-speed 1T 8051-based Flash MCU, 1 Kbytes SRAM, 16 Kbytes Flash, 128 bytes independent EEPROM, 23-channel low-power dual-mode TouchKey module, 12-bit ADC, Six 10-bit PWM Outputs, 3 Timer/Counters, MDU, UART, SSI, CheckSum module

1 General Description

The SC92F8463B/8462B/8461B (hereinafter referred to as the SC92F846XB) is a kind of enhanced high-speed 1T 8051-based industrial Flash Microcontroller unit (MCU) with integrated TouchKey function, in which the instruction system is completely compatible with standard 8051 product series.

The SC92F846XB has a 23-channel dual-mode capacitor TouchKey circuit with low power consumption. The TouchKey circuit can be operated under STOP Mode.

The SC92F846XB is integrated with 16K bytes Flash ROM, 1K bytes SRAM, 128 bytes EEPROM, up to 26 General-purpose I/Os (GPIO), 13 IO external interrupters, three 16-bit timers, 11-channel 12-bit high-precision ADC, 6-channel independent 10-bit PWM, internal $\pm 1\%$ high-precision 12/6/2MHz high-frequency oscillator and 4% precision low-frequency 128K oscillator, external crystal oscillator interface, one separate UART, one three-in-one serial communication interface which can be used as UART/SPI/TWI (SSI). To improve the reliability and simplify the circuit design, the SC92F846XB is also built in with 4-level optional LVR voltage, 2.4V ADC reference voltage and other high-reliability circuits.

The SC92F846XB features excellent anti-interference performance, which make it possible to be widely applied to industrial control system, such as intelligent home appliances, home automation, Internet of Things, wireless communication, gaming peripherals and consumer applications.

2 Features

Operating Voltage: 2.4V ~ 5.5V

Operating Temperature: -40 ~ 85°C

Package:

SC92F8463B (SOP28/TSSOP28)

SC92F8462B (SOP20/TSSOP20)

SC92F8461B (SOP16)

Core: 1T 8051

Flash ROM: 16K bytes Flash ROM (MOVC) prohibited addressing 0000H ~ 00FFH) can be rewritten for 10, 000 times

IAP: Code option into 0K, 0.5K, 1K or 16K

EEPROM: 128 bytes EEPROM can be rewritten for 100, 000 times. The data written-in has more than 10-year preservation life.

SRAM: Internal 256 bytes + external 768 bytes

System Clock (f_{SYS}):

- Built-in high-frequency 24MHz oscillator (f_{HRC}):
 - As the system clock source, f_{SYS} can be set to 12/6/2MHz by programmer selection.
 - Frequency Error: Suitable for 3.0V ~ 5.5V and -20 ~ 85°C application environment, no more than $\pm 1\%$ of frequency error
- Built-in high-frequency Crystal Oscillator Circuit
 - Available to externally connect 2-16 MHz Oscillator
 - As the source of system clock, f_{SYS} can be set to $/2$, $/4$ or $/12$ of the frequency of oscillator via code option.
- Operating voltage at different system frequency:
 - $>12\text{MHz}$ @2.9 ~ 5.5V
 - $\leq 12\text{MHz}$ @2.4 ~ 5.5V

Built-in Low-Frequency 128kHz Oscillator (LRC):

- Clock source of Base Timer (BTM), which can wake up the SC92F846XB from stop mode
- Clock source of Watchdog (WDT)
- Frequency Error: 4.0V ~ 5.5V and -20 ~ 85°C application environment, no more than $\pm 4\%$ of frequency error

Low-voltage Reset (LVR):

- 4-level LVR voltage options: 4.3V, 3.7V, 2.9V,

2.3V

- The default is the Code Option value selected by the user

Flash Programming and Emulation:

- 2-wire JTAG programming and emulation interface

Interruption (INT):

- 12 interrupt sources: Timer0, Timer1, Timer2, INT0 ~ 2, ADC, PWM, UART, SSI, Base Timer and TK
- 3 external interrupt vectors shared by 13 interrupt ports, all of which can be defined in rising-edge, falling-edge or dual-edge trigger mode.
- Two-level interrupt priority capability

Digital Peripheral:

- Up to 26 bidirectional independently controllable I/O interfaces, able to configure pull-high resistor independently
- P0/P2 ports with 4-level drive capability
- All I/Os equipped with sink current drive capability (70 mA)
- 11-bit WDT with optional clock division ratio
- 3 standard 80C51 Timer/Counters: Timer0, Timer1 and Timer2
- Timer2 can be set to capture mode
- Six 10-bit PWM output channels with variable period and individual duty cycle, which can simultaneously output three sets of complementary PWM waveforms with dead zone
- 5 I/Os as output of the 1/2-bias LCD COM
- 1 independent UART communication interface (Switchable I/O port)
- 1 three-in-one serial communication interface

(SSI) (Switchable I/O port)

- 16*16-bit hardware multiplier and divider unit (MDU)

Analog Peripheral:

- The 23-channel dual-mode TouchKey (TK) circuit with low power consumption can be configured in high sensitivity mode or high reliability mode:
 - High-sensitivity mode applicable to TouchKey sensor, proximity induction and other TouchKey applications featuring high requirements on sensitivity
 - High reliability mode features very strong anti-interference which is able to pass 10V dynamic CS test
 - Implementing 23-channel high-sensitivity TouchKeys and derivative functions
 - High-flexibility development with software library support to reduce development difficulty
 - Supporting automatic debugging software and intelligent development
 - When scanning with a single TouchKey in stop mode, the overall power consumption of the chip can be as low as 11uA
- 11-channel 12-bit ± 2 LSB ADC
 - Built-in 2.4V reference voltage
 - 2 options for ADC reference voltage: V_{DD} and internal 2.4V
 - Internal one-channel ADC, where V_{DD} can be measured directly
 - ADC conversion completion interrupt

Power Saving Mode:

- IDLE Mode: can be woken up by any interrupt.
- STOP Mode: can be woken up by INT0 ~ 2, Base Timer and TK

Naming Rules for 92 Series Products

Name	SC	92	F	8	4	6	3	B	M	28	U
S/R	①	②	③	④	⑤	⑥	⑦	⑧	⑨	⑩	⑪

S/R	Meaning
①	SinOne Chip abbreviation
②	Name of product series
③	Product Type (F: Flash MCU)
④	Serial Number: 7: GP Series, 8: TK series
⑤	ROM Size: 1 for 2K, 2 for 4K, 3 for 8K, 4 for 16K and 5 for 32K...
⑥	Subseries Number.: 0 ~ 9, A ~ Z
⑦	Number of Pins: 0: 8pin, 1: 16pin, 2: 20pin, 3: 28pin, 5: 32pin, 6: 44pin, 7: 48pin, 8: 64pin, 9: 100pin
⑧	Version Number: (default, B, C, D)
⑨	Package Type: (D: DIP; M: SOP; X: TSSOP; F: QFP; P: LQFP; Q: QFN; K: SKDIP)
⑩	Number of Pins.
⑪	Packaging Mode: (U: Tube; R: Tray; T: Reel)

Contents

1 General Description	1
2 Features	1
Naming Rules for 92 Series Products	3
Contents	4
3 Pin Description.....	8
3.1 Pin Configuration	8
3.2 Pin Definition	9
4 Inner BLOCK Diagram	14
5 Flash ROM and SRAM Structure	15
5.1 Flash ROM	15
5.2 Customer Option Memory (User Programming Setting)	16
5.2.1 Customer-Option-related Registers Operation Instructions	19
5.3 SRAM.....	20
5.3.1 Internal 256 bytes SRAM.....	20
5.3.2 External 768 bytes SRAM.....	22
6 Special Function Register (SFR)	23
6.1 SFR Mapping	23
6.2 SFR Instructions	24
6.2.1 C51 Core SFRs	29
7 Power, Reset and System Clock.....	31
7.1 Power Circuit.....	31
7.2 Power-on Reset.....	31
7.2.1 Reset Stage	31
7.2.2 Loading Information Stage.....	31
7.2.3 Normal Operating Stage	31
7.3 Reset Modes.....	31
7.3.1 External Reset	32
7.3.2 Low-voltage Reset (LVR).....	32
7.3.3 Power-on Reset (POR).....	33
7.3.4 Watchdog Reset (WDT).....	33
7.3.5 Register Reset Value	35
7.4 High-speed RC Oscillator.....	37

7.5 Low-speed RC Oscillator	41
7.6 Power Saving Modes	42
8. CPU and Function System	44
8.1 CPU.....	44
8.2 Addressing Mode.....	44
8.2.1 Immediate Addressing	44
8.2.2 Direct Addressing	44
8.2.3 Indirect Addressing	44
8.2.4 Register Addressing	44
8.2.5 Relative Addressing.....	44
8.2.6 Indexed Addressing	45
8.2.7 Bits Addressing.....	45
9 Interrupt	46
9.1 Interrupt Source and Vector	46
9.2 Interrupt Structure Diagram.....	48
9.3 Interrupt Priority.....	49
9.4 Interrupt Processing Flow.....	49
9.5 Interrupt-related Registers.....	49
10 Timer/Counter T0 and T1	59
10.1 T0 and T1-related Registers.....	59
10.2 T0 Operating Modes	65
10.3 T1 Operating Modes	66
11 Timer/Counter T2	68
11.1 T2-related Registers	68
11.2 T2 Operating Modes	73
12 Multiplier-Divider Unit (MDU)	77
13 PWM	79
13.1 PWM block Diagram	79
13.2 PWM-related Registers.....	80
13.3 PWM General Configuration Registers.....	81
13.4 PWM Independent Mode	85
13.4.1 PWM Independent Mode Diagram	85
13.4.2 PWM Independent Mode Duty cycle Configuration.....	86

13.5 PWM Complementary Mode.....	89
13.5.1 PWM Complementary Mode Diagram.....	89
13.5.2 PWM duty cycle Configuration in complementary mode.....	90
13.5.3 PWM Dead Zone Time Configuration in Complementary Mode.....	91
13.5.4 PWM Dead-time Output Waveform.....	92
13.6 PWM Waveforms and Directions.....	93
14 General-purpose I/O (GPIO).....	95
14.1 GPIO Structure Diagram.....	95
14.2 I/O Port-related Registers.....	96
15 Software LCD Driver.....	101
15.1 Software LCD Drives-related Registers.....	101
16 Serial Interface 0 (UART0).....	103
16.1 Baud Rate of Serial Communication.....	105
17 SPI/TWI/UART Serial Interface (SSI).....	106
17.1 Serial Peripheral Interface (SPI).....	107
17.1.1 SPI Operation-related Registers.....	107
17.1.2 Signal Description.....	110
17.1.3 Operating Modes.....	110
17.1.4 Transfer Form.....	111
17.1.5 Error Detection.....	112
17.2 Two-Wire Interface (TWI).....	113
17.2.1 Signal Description.....	115
17.2.2 Operating Modes.....	115
17.2.3 Operating Steps.....	118
17.3 Serial Interface 1 (UART1).....	119
18 Analog-to-Digital Converter (ADC).....	122
18.1 ADC-related Registers.....	122
18.2 ADC Conversion Steps.....	128
19 Dual-mode TouchKey Module.....	129
19.1 Power Saving Modes of TouchKey Module.....	129
19.2 TouchKey Mode.....	130
20 EEPROM and IAP Operations.....	131
20.1 EEPROM / IAP Operating-related Registers.....	132
20.2 EEPROM / IAP Operating Procedures:.....	136

20.2.1 128 bytes Independent EEPROM Operating Demo program	137
20.2.2 16K bytes Code memory IAP Operating Demo program	138
21 CheckSum Module	139
21.1 CheckSum-Related Registers.....	139
22 Electrical Characteristics	141
22.1 Absolute Maximum Ratings.....	141
22.2 Recommended Operating Conditions	141
22.3 DC Characteristics.....	141
22.4 AC Characteristics.....	146
22.5 ADC Characteristics	146
23 Application Circuit	148
24 Ordering Information	149
25 Packageing Information	150
26 Revision History.....	160

Preliminary

3 Pin Description

3.1 Pin Configuration

Note: In consideration of multiplexing of TK20/TK21 and TK debugging communication ports of the SC92F846XB, if it is required to use the TK debugging function, please avoid using TK20/TK21!

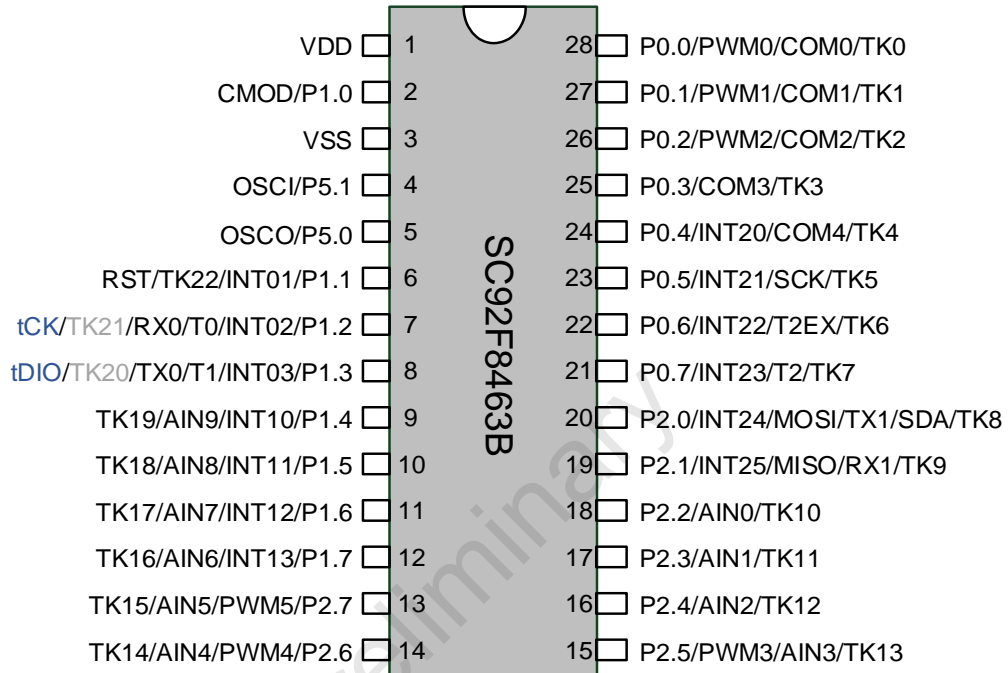

The SC92F8463B Pin Diagram

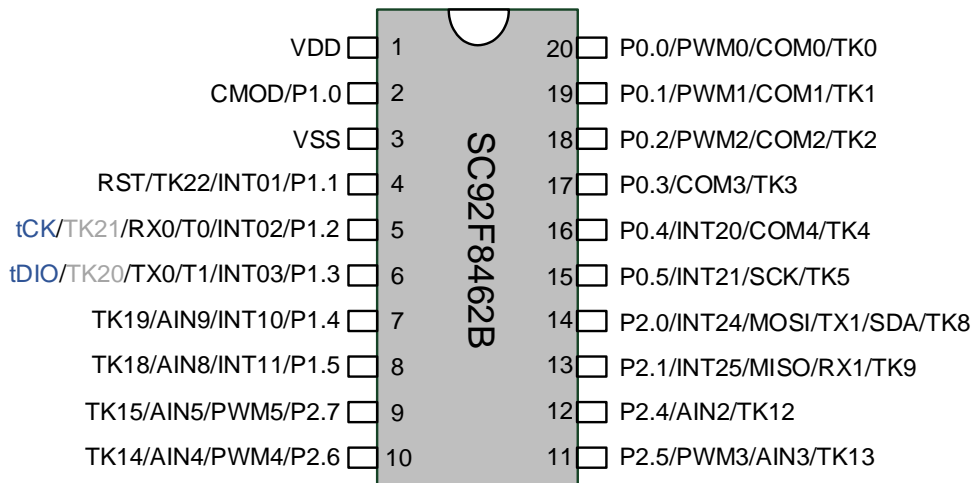

The SC92F8462B Pin Diagram

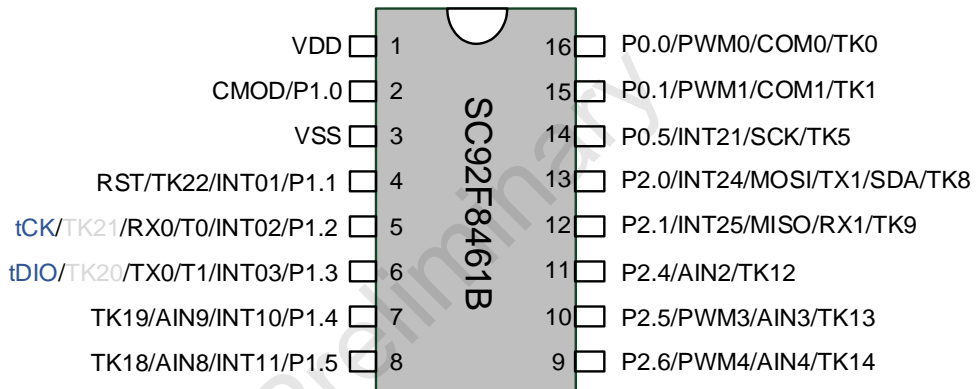

The SC92F8461B Pin Diagram

3.2 Pin Definition

Pin number			Pin Name	Type	Description
28PIN	20PIN	16PIN			
1	1	1	VDD	Power	Power
2	2	2	P1.0/CMOD	I/O	P1.0: GPIO P1.0 CMOD: Touch Key External Capacitance
3	3	3	VSS	Power	Ground

4	-	-	P5.1/OSCI	I/O	P5.1: GPIO P5.1 OSCI: External crystal oscillator input
5	-	-	P5.0/OSCO	I/O	P5.0: GPIO P5.0 OSCO: External crystal oscillator output
6	4	4	P1.1/INT01/TK22/RST	I/O	P1.1: GPIO P 1.1 INT01: Input 1 of external interrupt 0 TK22: TK Channel 22 RST: Reset Pin
7	5	5	P1.2/INT02/T0/RX0/TK21/tCK	I/O	P1.2: GPIO P1.2 INT02: Input 2 of external interrupt 0 T0: Timer/Counter 0 External Input RX0: UART0 Receiver TK21: TK channel 21, if it is required to use the TK debugging function, please avoid using TK21 tCK: Programming and Emulation Clock Pin
8	6	6	P1.3/INT03/T1/TX0/TK20/tDIO	I/O	P1.3: GPIO P1.3 INT03: Input 3 of external interrupt 0 T1: Timer/Counter 1 External Input TX0: UART 0 Transmitter- TK20: TK channel 20, if it is required to use the TK debugging function, please avoid using TK20 tDIO: Programming and Emulation Data Pin
9	7	7	P1.4/INT10/AIN9/TK19	I/O	P1.4: GPIO P1.4 INT10: Input 0 of external interrupt 1 AIN9: ADC Input Channel 9

					TK19: TK Channel 19
10	8	8	P1.5/INT11/AIN8/TK18	I/O	P1.5: GPIO P1.5 INT11: Input 1 of external interrupt 1 AIN8: ADC Input Channel 8 TK18: TK Channel 18
11	-	-	P1.6/INT12/AIN7/TK17	I/O	P1.6: GPIO P1.6 INT12: Input 2 of external interrupt 1 AIN7: ADC Input Channel 7 TK17: TK Channel 17
12	-	-	P1.7/INT13/AIN6/TK16	I/O	P1.7: GPIO P1.7 INT13: Input 3 of external interrupt 1 AIN6: ADC Input Channel 6 TK16: TK Channel 16
13	9	-	P2.7/PWM5/AIN5/TK15	I/O	P2.7: GPIO P2.7 PWM5: PWM5 Output AIN5: ADC Input Channel 5 TK15: TK Channel 15
14	10	9	P2.6/PWM4/AIN4/TK14	I/O	P2.6: GPIO P2.6 PWM4: PWM4 Output AIN4: ADC Input Channel 4 TK14: TK Channel 14
15	11	10	P2.5/PWM3/AIN3/TK13	I/O	P2.5: GPIO P2.5 PWM3: PWM3 Output AIN3: ADC Input Channel 3 TK13: TK Channel 13
16	12	11	P2.4/AIN2/TK12	I/O	P2.4: GPIO P2.4

					AIN2: ADC Input Channel 2 TK12: TK Channel 12
17	-	-	P2.3/AIN1/TK11	I/O	P2.3: GPIO P 2.3 AIN1: ADC Input Channel 1 TK11: TK Channel 11
18	-	-	P2.2/AIN0/TK10	I/O	P2.2: GPIO P2.2 AIN0: ADC Input Channel 0 TK10: TK Channel 10
19	13	12	P2.1/INT25/MISO/RX1/TK9	I/O	P2.1: GPIO P2.1 INT25: Input 5 of external interrupt 2 MISO: SPI master-in/slave-out RX1: UART1 Receiver TK9: TK Channel 9
20	14	13	P2.0/INT24/MOSI/TX1/SDA/TK8	I/O	P2.0: GPIO P2.0 INT24: Input 4 of external interrupt 2 MOSI: SPI master-out/slave-in TX1: UART1 Transmitter SDA: SDA for TWI TK8: TK Channel 8
21	-	-	P0.7/INT23/T2/TK7	I/O	P0.7: GPIO P 0.7 INT23: Input 3 of external interrupt 2 T2: Timer/Counter 2 External input TK7: TK Channel 7
22	-	-	P0.6/INT22/T2EX/TK6	I/O	P0.6: GPIO P0.6 INT22: Input 2 of external interrupt 2 T2EX: External Signal Input Capture for Timer2

					TK6: TK Channel 6
23	15	14	P0.5/INT21/SCK/TK5	I/O	P0.5: GPIO P0.5 INT21: Input 1 of external interrupt 2 SCK: SCK for SPI and TWI TK5: TK Channel 5
24	16	-	P0.4/INT20/COM4/TK4	I/O	P0.4: GPIO P0.4 INT20: Input 0 of external interrupt 2 COM4: LCD common drive output 4 TK4: TK Channel 4
25	17	-	P0.3/COM3/TK3	I/O	P0.3: GPIO P0.3 COM3: LCD common drive output 3 TK3: TK Channel 3
26	18	-	P0.2/PWM2/COM2/TK2	I/O	P0.2: GPIO P0.2 PWM2: PWM2 output COM2: LCD common drive output 2 TK2: TK Channel 2
27	19	15	P0.1/PWM1/COM1/TK1	I/O	P0.1: GPIO P0.1 PWM1: PWM1 output COM1: LCD common drive output 1 TK1: TK Channel 1
28	20	16	P0.0/PWM0/COM0/TK0	I/O	P0.0: GPIO P0.0 PWM0: PWM0 output COM0: LCD common drive output 0 TK0: TK Channel 0

4 Inner BLOCK Diagram

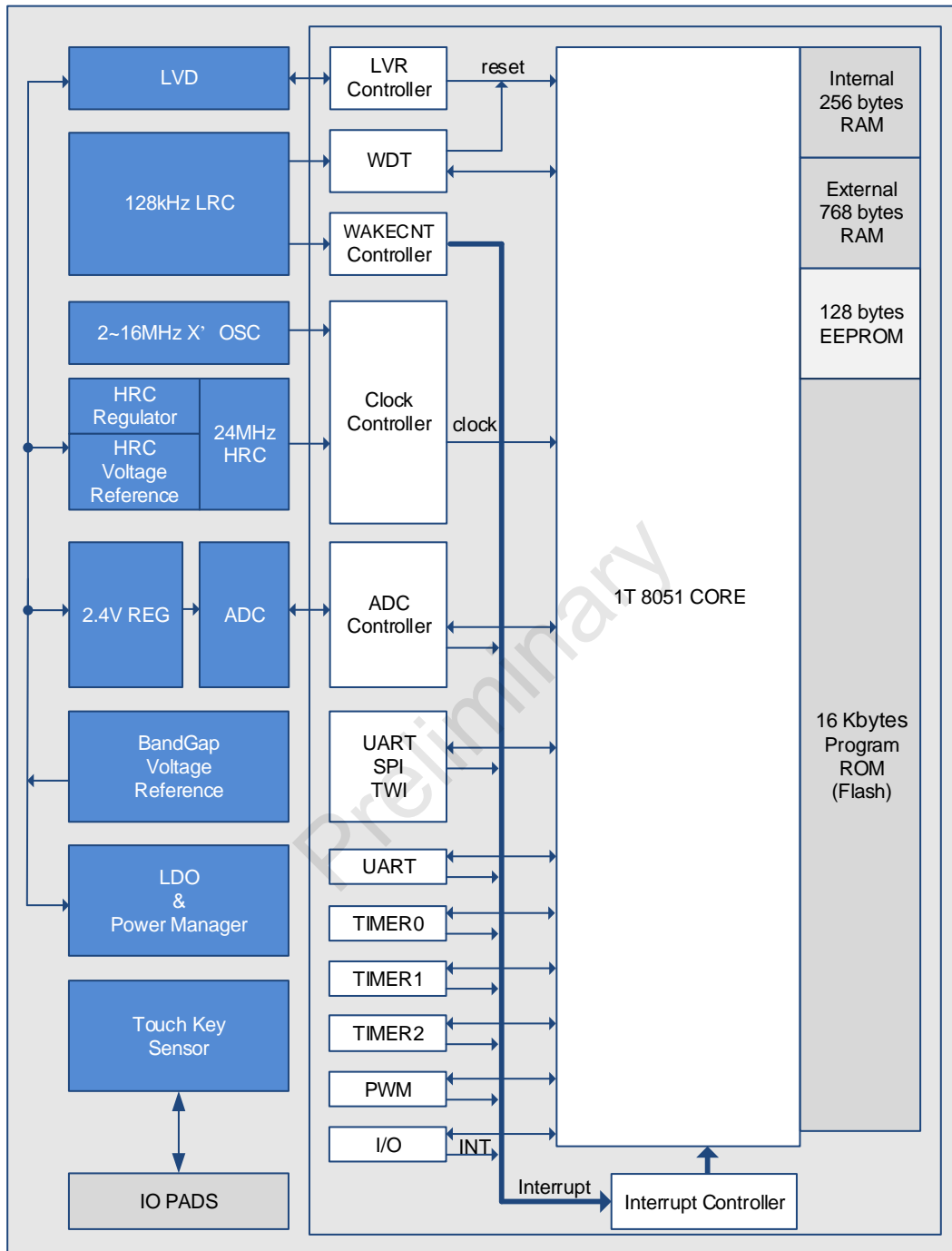

The SC92F846XB BLOCK DIAGRAM

5 Flash ROM and SRAM Structure

The structures of the SC92F846XB's Flash ROM and SRAM are shown as follows:

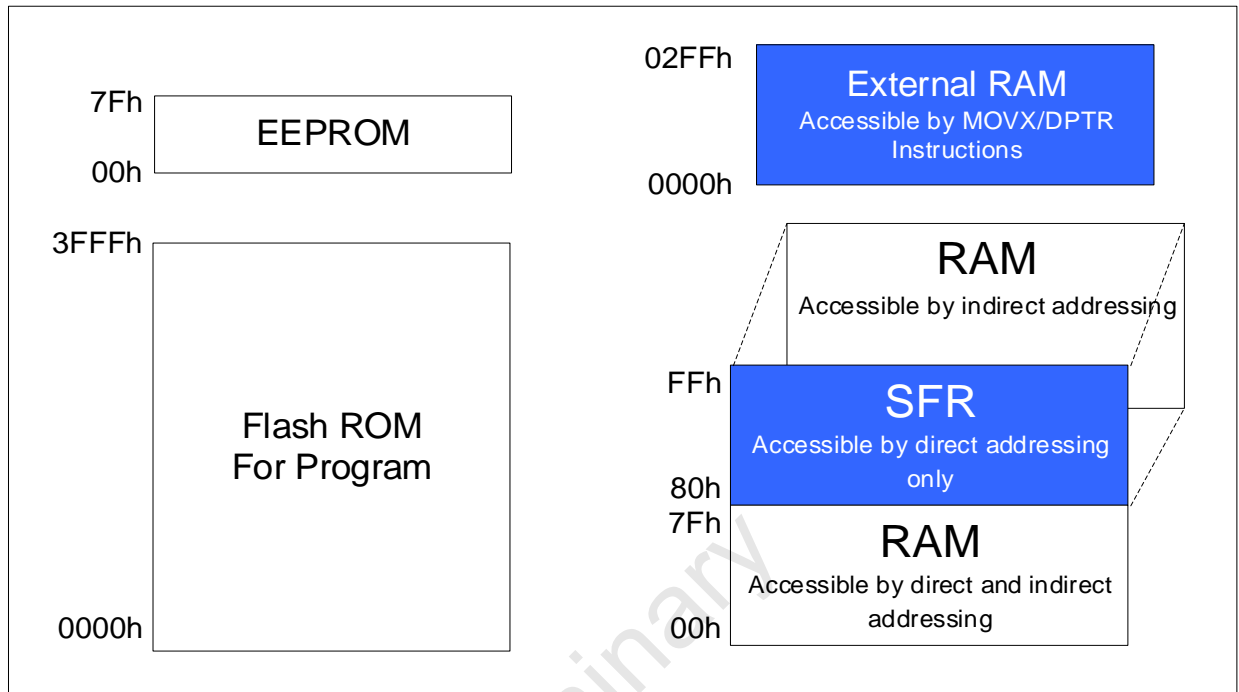

Flash ROM and SRAM Structure Diagram

5.1 Flash ROM

The SC92F846XB provides 16 Kbytes of Flash ROM with the ROM address of 0000H ~ 3FFFH. These 16 Kbytes of Flash ROM can be rewritten 10,000 times, which is able to program and erase by specialized ICP programming device (SOC PRO52/DPT52/SC LINK) provided by SinOne.

The MOVC instruction is non-addressable within 256 bytes (address of 0000H ~ 00FFH). That is to say, it is unable to read the contents of the 256 bytes region by program, so as to realize the encryption function of chip program. For more details, refer to "SinOne SC92F Series MCU Application Guide".

EEPROM is an data memory separated from 16K bytes ROM with the address of 00H ~ 7FH, which can be accessed by single-byte reading and writing operations in the program; for more details, refer to [20 EEPROM and IAP Operations](#). Note: The number of erasure of EEPROM is 100,000 times. The user should not exceed the rated burn number of EEPROM, otherwise there will be an exception!

The SC92F846XB 16 Kbytes Flash ROM provide Empty Check, Program, Verify and Erase function other than Read function. This Flash ROM and EEPROM usually needs no Erase operation before writing. Directly writing data can realize coverage of new data.

The SC92F846XB Flash ROM can be programmed by **tDIO**, **tCK**, **VDD** and **VSS**, with its specific connection shown as follows:

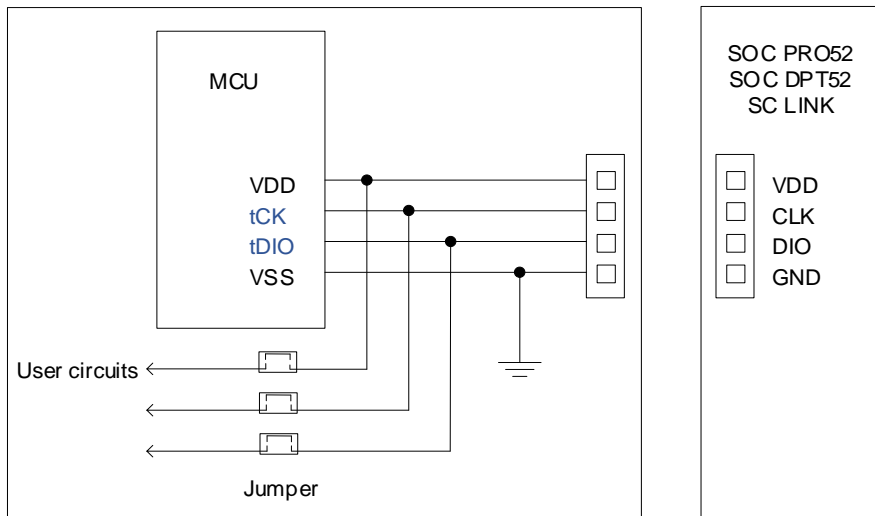

ICP Mode Flash Writer Programming Connection Diagram

5.2 Customer Option Memory (User Programming Setting)

A separate Flash data memory is embedded inside the SC92F846XB, called Code Option area, to save the user's presets. These presets will be written into IC when programming and loaded into SFR as default values during reset.

Option-related SFR Operating Instructions:

Reading and writing operations to option-related SFR are controlled by both register OPINX and register OPREG, with its respective address of Option SFR depending on register OPINX, as shown below:

Symbol	Address	Description	7	6	5	4	3	2	1	0
OP_HRCR	83H@FFH	System Clock Change Register	OP_HRCR[7: 0]							
OP_CTM0	C1H@FFH	Customer Option Register 0	ENWDT	ENXTL	SCLKS[1: 0]		DISRST	DISLVR	LVRS[1: 0]	
OP_CTM1	C2H@FFH	Customer Option Register 1	VREFS	XTLHF	-	-	IAPS[1: 0]		-	-

OP_HRCR (83H@FFH) System Clock Change Register (Read/Write)

Bit Number	7	6	5	4	3	2	1	0
Bit Mnemonic	OP_HRCR[7: 0]							

R/W	R/W							
POR	n	n	n	n	n	n	n	n

Bit Number	Bit Mnemonic	Description
7 ~ 0	OP_HRCR[7: 0]	Internal high-frequency RC frequency adjustment Central value 10000000b corresponds to HRC central frequency, the larger the value is, the faster the frequency will be, vice versa.

OP_CTM0 (C1H@FFH) Customer Option Register0 (Read/Write)

Bit Number	7	6	5	4	3	2	1	0
Bit Mnemonic	ENWDT	ENXTL	SCLKS[1: 0]		DISRST	DISLVR	LVRS[1: 0]	
R/W	R/W	R/W	R/W		R/W	R/W	R/W	
POR	n	n	n		n	n	n	

Bit Number	Bit Mnemonic	Description
7	ENWDT	Watchdog (WDT) control bit (This bit is transferred by the system to the value set by the user Code Option) 0: WDT invalid 1: WDT valid (WDT stops counting during IAP execution)
6	ENXTL	External High-Frequency crystal oscillator selection bit 0: External High-Frequency crystal Interface disable, P5.0 and P5.1 valid 1: External High-Frequency crystal Interface enable, P5.0 and P5.1 invalid

5 ~ 4	SCLKS[1: 0]	System clock frequency selection bits 00: Reserved; 01: System clock frequency is HRC frequency divided by 2; 10: System clock frequency is HRC frequency divided by 4; 11: System clock frequency is HRC frequency divided by 12;
3	DISRST	IO/RST selection bit 0: configure P1.1 as External Reset input pin 1: configure P1.1 as GPIO
2	DISLVR	LVR control bit 0: LVR valid 1: LVR invalid
1 ~ 0	LVRs [1: 0]	LVR voltage selection bits 11: 4.3V reset 10: 3.7 V reset 01: 2.9V reset 00: 2.3 V reset

OP_CTM1 (C2H@FFH) Customer Option Register1 (Read/Write)

Bit Number	7	6	5	4	3	2	1	0
Bit Mnemonic	VREFS	XTLHF	-	-	IAPS[1: 0]		-	-
R/W	R/W	R/W	-	-	R/W	R/W	-	-
POR	n	n	x	x	n	n	x	x

Bit Number	Bit Mnemonic	Description
7	VREFS	Reference voltage selection bit (Initial values are configured by the user and loaded from Code Options) 0: Configure ADC VREF as V _{DD} 1: Configure ADC VREF as internally correct 2.4V
6	XTLHF	External clock source frequency mode register selection bit 0: Match with the external clock source which frequency <12M 1: Match with the external clock source which frequency ≥12M
3 ~ 2	IAPS[1: 0]	EEPROM and IAP Area Selection Bits 00: Code memory prohibits IAP operations, only EEPROM data memory is used for data storage 01: last 0.5k code memory allows IAP operation (3E00H ~ 3FFFH) 10: Last 1k code memory allows IAP operation (3C00H ~ 3FFFH) 11: All code memory allows IAP operation (0000H ~ 3FFFH)
5 ~ 4, 1 ~ 0	-	Reserved

5.2.1 Customer-Option-related Registers Operation Instructions

Option-related SFRs reading and writing operations are controlled by both OPINX and OPREG registers, with their respective position of Option SFR depending on OPINX and its value written to option-related SFR depending on register OPREG:

Symbol	Address	Description		POR
OPINX	FEH	Option Pointer	OPINX[7: 0]	00000000b
OPREG	FFH	Option Register	OPREG[7: 0]	nnnnnnnb

When operating Option-related SFRs, register OPINX stores the address of option-related registers and register OPREG stores corresponding value.

For example: To configure OP_HRCR as 0x01, specific operation method is shown below:

C program example:

```
OPINX = 0x83;           //Write OP_HRCR address into OPINX register
```

```
OPREG = 0x01;           //Write 0x01 into OPREG register (the value to be written into OP_HRCR register)
```

Assembler program example:

```
MOV OPINX, #83H         ;Write OP_HRCR address into OPINX register
```

```
MOV OPREG, #01H        ;Write 0x01 into OPREG register (the value to be written into OP_HRCR register)
```

Note: It is forbidden to write any value beyond SFR address of Customer Option region into OPINX register! Or else, it may cause abnormal system operation.

5.3 SRAM

The SC92F846XB Microcontroller Unit, which integrates SRAM of 1 Kbytes, is divided into internal 256 bytes RAM and external 768 bytes RAM. The address of Internal RAM range from 00H to FFH, including high 128 bytes (address of from 80H to FFH) only addressed indirectly and low 128 bytes (address of from 00H to 7FH) addressed both directly and indirectly).

The address of SFRs is also from 80H to FFH. But the difference between SFR and internal high 128 bytes SRAM is that the former is addressed directly but the latter addressed indirectly only.

The address of External RAM from 0000H to 02FFH, which is addressed by MOVX instruction.

5.3.1 Internal 256 bytes SRAM

Internal low 128 bytes SRAM area is divided into three parts: ① Register bank 0 ~ 3, address from 00H to 1FH. The active bank is selected by bits RS1 and RS0 of PSW register. Using Register bank 0 ~ 3 can accelerate arithmetic speed; ② Bit addressing area, 20H ~ 2FH; user can use it as normal RAM or bitwise addressing RAM; for the latter, the bit address is from 00H to 7FH (bitwise addressing is different from normal SRAM byte-oriented addressing), which can be distinguished by instructions in program; ③ User RAM and stack area, the 8-bit stack pointer will point to stack area after the SC92F846XB reset; in general, users can set initial value in initializer, which is recommended to configure in the unit interval from E0H to FFH.

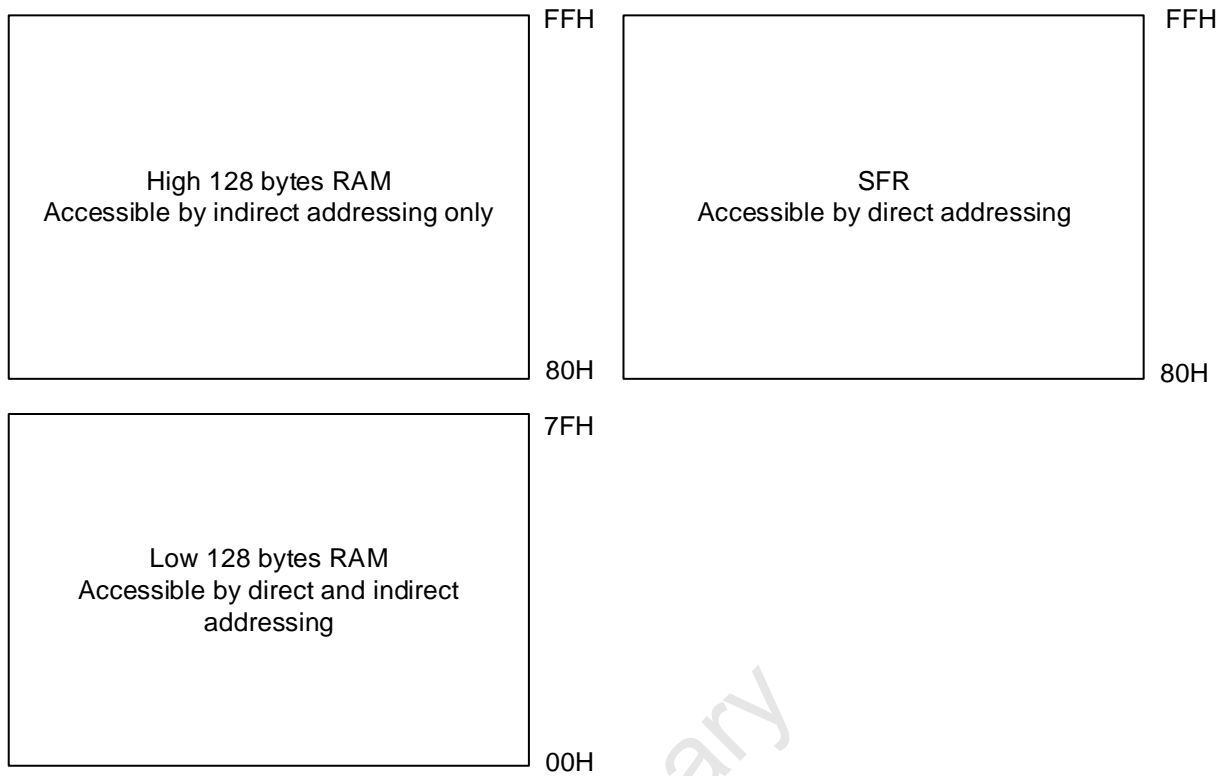

Internal 256 bytes RAM Structure Diagram

Internal low 128 bytes RAM structure is shown below:

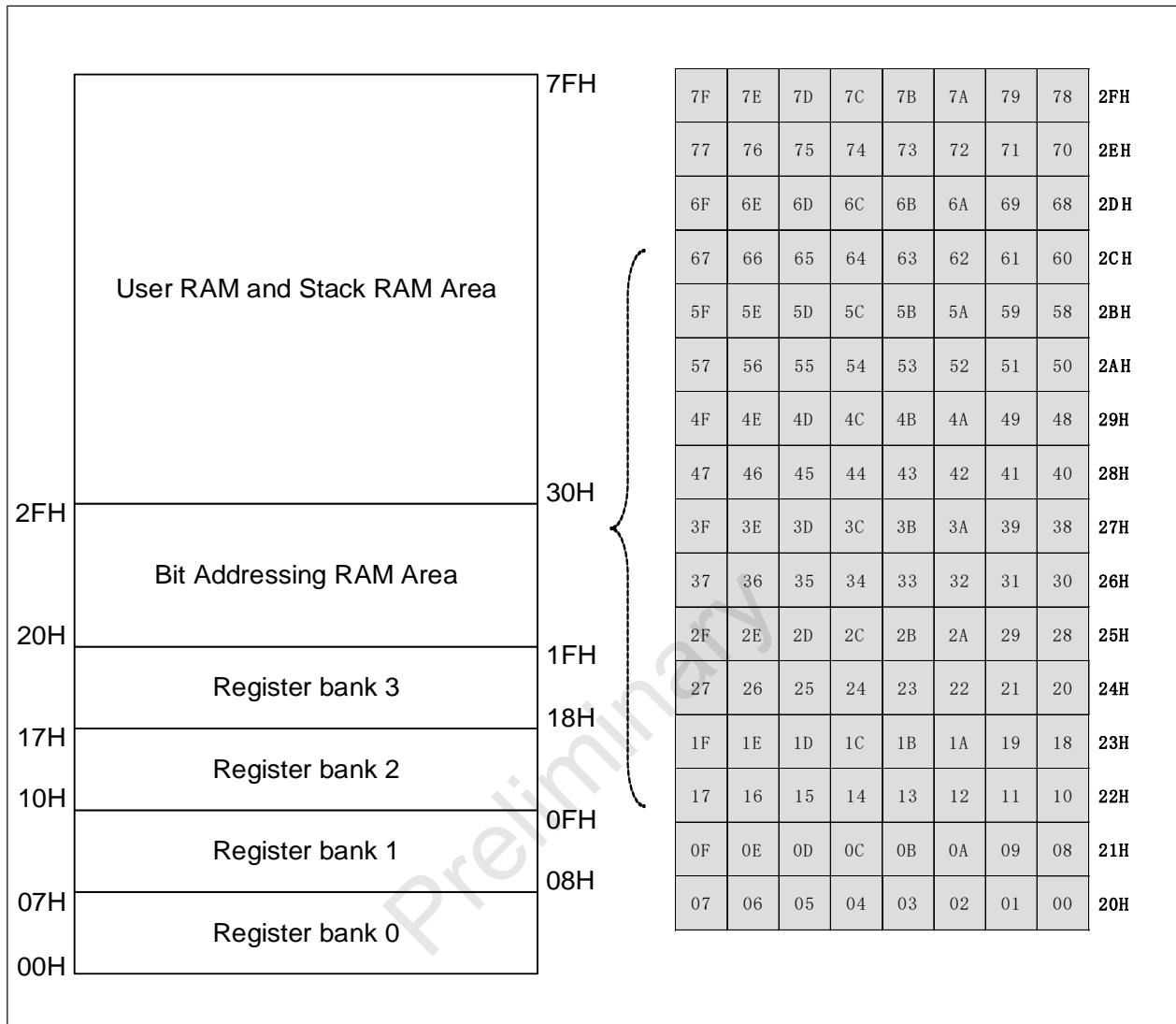

SRAM Structure Diagram

5.3.2 External 768 bytes SRAM

The external 768 bytes RAM (SRAM) can be accessed by instruction "MOVX @DPTR" or instruction MOVX A, @Ri or MOVX @Ri, A together with EXADH register. EXADH register stores high address of external SRAM; Ri register stores low 8-bit address of external SRAM.

EXADH (F7H) External SRAM Operating Address High (Read/Write)

Bit Number	7	6	5	4	3	2	1	0
Bit Mnemonic	-	-	-	-	-	EXADH [1:0]		

POR	x	x	x	x	x	0	0	0
-----	---	---	---	---	---	---	---	---

Bit Number	Bit Mnemonic	Description
1 ~ 0	EXADH [1: 0]	External SRAM Address High position
7 ~ 2	-	Reserved

6 Special Function Register (SFR)

6.1 SFR Mapping

The SC92F846XB provides some registers equipped with special functions, called SFR. The address of such SFRs is from 80H to FFH, some are bit-addressable, and others are not. It is very convenient for these bit addressable registers to change the value of single bit, of which the address is end up with figure "0" or "8". All SFR shall use direct addressing for addressing.

The name and address of the SC92F846XB special function registers are shown in the table below:

	0/8	1/9	2/A	3/B	4/C	5/D	6/E	7/F
F8h	-	-	-	-	CHKSUML	CHKSUMH	OPINX	OPREG
F0h	B	IAPKEY	IAPADL	IAPADH	IAPADE	IAPDAT	IAPCTL	EXADH
E8h	-	EXA0	EXA1	EXA2	EXA3	EXBL	EXBH	OPERCON
E0h	ACC	-	-	-	-	-	-	-
D8h	P5	P5CON	P5PH	-	PWMDTYB	PWMDTY3	PWMDTY4	PWMDTY5
D0h	PSW	PWMCFG	PWMCON	PWMPRD	PWMDTYA	PWMDTY0	PWMDTY1	PWMDTY2
C8h	T2CON	T2MOD	RCAP2L	RCAP2H	TL2	TH2	BTMCON	WDTCON
C0h	-	-	-	-	-	-	INT2F	INT2R
B8h	IP	IP1	INT0F	INT0R	INT1F	INT1R	-	-

B0h	-	-	-	-	-	-	-	-
A8h	IE	IE1	ADCCFG2	ADCCFG0	ADCCFG1	ADCCON	ADCVL	ADCVH
A0h	P2	P2CON	P2PH	-	-	-	-	-
98h	SCON	SBUF	P0CON	P0PH	P0VO	SSCON0	SSCON1	SSDAT
90h	P1	P1CON	P1PH	-	-	SSCON2	-	IOHCON
88h	TCON	TMOD	TL0	TL1	TH0	TH1	TMCON	OTCON
80h	P0	SP	DPL	DPH	-	-	-	PCON
	Bit Addressable	Not Bit Addressable						

Notes:

1. Hollow space of SFR refers to the fact that there is no such register RAM, it is not recommended for user to use.
2. The address of SFR for system configuration is F1H ~ FFH, user use it may result in system exceptions. User are not allowed to conduct clearing or other operations to these registers during the system initialization process.

6.2 SFR Instructions

For a description of each SFR, see the following table:

Mnemonic	Add	Description	7	6	5	4	3	2	1	0	POR
P0	80H	P0 Data Register	P07	P06	P05	P04	P03	P02	P01	P00	0000000b
SP	81H	Stack Pointer	SP[7: 0]								0000011b
DPL	82H	Data Pointer Low byte	DPL[7: 0]								0000000b
DPH	83H	Data Pointer High byte	DPH[7: 0]								0000000b
PCON	87H	Power Management Control Register	SMOD	-	-	-	-	-	STOP	IDL	0xxxx00b
TCON	88H	Timer Control Register	TF1	TR1	TF0	TR0	IE1	-	IE0	-	00000x0xb

TMOD	89H	Timer Operating Mode Register	-	C/T1	M11	M01	-	C/T0	M10	M00	x000x000b
TL0	8AH	Timer0 Low 8 bits	TL0[7: 0]								00000000b
TL1	8BH	Timer1 Low 8 bits	TL1[7: 0]								00000000b
TH0	8CH	Timer0 High 8 bits	TH0[7: 0]								00000000b
TH1	8DH	Timer1 High 8 bits	TH1[7: 0]								00000000b
TMCON	8EH	Timer Frequency Control Register	-	-	-	-	-	T2FD	T1FD	T0FD	xxxxx000b
OTCON	8FH	Output Control Register	SSMOD[1: 0]		-	-	VOIRS[1: 0]		-	-	00xx00xxb
P1	90H	P1 Data Register	P17	P16	P15	P14	P13	P12	P11	P10	00000000b
P1CON	91H	P1 I/O Control Register	P1C7	P1C6	P1C5	P1C4	P1C3	P1C2	P1C1	P1C0	00000000b
P1PH	92H	P1 Pull-up Resistor Control Register	P1H7	P1H6	P1H5	P1H4	P1H3	P1H2	P1H1	P1H0	00000000b
SSCON2	95H	SSI Control Register 2	SSCON2[7: 0]								00000000b
IOHCON	97H	IOH Setup Register	P2H[1: 0]		P2L[1: 0]		P0H[1: 0]		P0L[1: 0]		00000000b
SCON	98H	Serial Port Control Register	SM0	SM1	SM2	REN	TB8	RB8	TI	RI	00000000b
SBUF	99H	Serial Port Data Cache Register	SBUF[7: 0]								00000000b
P0CON	9AH	P0 I/O Control Register	P0C7	P0C6	P0C5	P0C4	P0C3	P0C2	P0C1	P0C0	00000000b
P0PH	9BH	P0 Pull-up Resistor Control Register	P0H7	P0H6	P0H5	P0H4	P0H3	P0H2	P0H1	P0H0	00000000b
P0VO	9CH	P0 Port LCD Voltage Output Register	-	-	-	P04VO	P03VO	P02VO	P01VO	P00VO	xxx00000b
SSCON0	9DH	SSI Control Register 0	SSCON0[7: 0]								00000000b
SSCON1	9EH	SSI Control Register 1	SSCON1[7: 0]								00000000b
SSDAT	9FH	SSI Data Register	SSD[7: 0]								00000000b

P2	A0H	P2 Data Register	P27	P26	P25	P24	P23	P22	P21	P20	00000000b
P2CON	A1H	P2 I/O Control Register	P2C7	P2C6	P2C5	P2C4	P2C3	P2C2	P2C1	P2C0	00000000b
P2PH	A2H	P2 Pull-up Resistor Control Register	P2H7	P2H6	P2H5	P2H4	P2H3	P2H2	P2H1	P2H0	00000000b
IE	A8H	Interrupt Enable Register	EA	EADC	ET2	EUART	ET1	EINT1	ET0	EINT0	00000000b
IE1	A9H	Interrupt Enable Register 1	-	-	-	ETK	EINT2	EBTM	EPWM	ESSI	xxx00000b
ADCCFG2	AAH	ADC Configuration Register 2	-	-	-	-	LOWSP	ADCCK[2: 0]			xxxx0000b
ADCCFG0	ABH	ADC Configuration Register 0	EAIN7	EAIN6	EAIN5	EAIN4	EAIN3	EAIN2	EAIN1	EAIN0	00000000b
ADCCFG1	ACH	ADC Configuration Register 1	-	-	-	-	-	-	EAIN9	EAIN8	xxxxx00b
ADCCON	ADH	ADC Control Register	ADCEN	ADCS	EOC/ADCIF	ADCIS[4: 0]					00000000b
ADCVL	AEH	ADC Result Register	ADCV[3: 0]				-	-	-	-	0000xxxxb
ADCVH	AFH	ADC Result Register	ADCV[11: 4]								00000000b
IP	B8H	Interrupt Priority Control Register	-	IPADC	IPT2	IPUART	IPT1	IPINT1	IPT0	IPINT0	x0000000b
IP1	B9H	Interrupt Priority Control Register 1	-	-	-	IPTK	IPINT2	IPBTM	IPPWM	IPSSI	xxx00000b
INT0F	BAH	INT0 Falling Edge Interrupt Control Register	-	-	-	-	INT0F3	INT0F2	INT0F1	-	xxxx000xb
INT0R	BBH	INT0 Rising Edge Interrupt Control Register	-	-	-	-	INT0R3	INT0R2	INT0R1	-	xxxx000xb
INT1F	BCH	INT1 Falling Edge Interrupt Control Register	-	-	-	-	INT1F3	INT1F2	INT1F1	INT1F0	xxxx0000b
INT1R	BDH	INT1 Rising Edge Interrupt Control Register	-	-	-	-	INT1R3	INT1R2	INT1R1	INT1R0	xxxx0000b
INT2F	C6H	INT2 Falling Edge Interrupt Control Register	-	-	INT2F5	INT2F4	INT2F3	INT2F2	INT2F1	INT2F0	xx000000b
INT2R	C7H	INT2 Rising Edge Interrupt Control Register	-	-	INT2R5	INT2R4	INT2R3	INT2R2	INT2R1	INT2R0	xx000000b

T2CON	C8H	Timer2 Control Register	TF2	EXF2	RCLK	TCLK	EXEN2	TR2	C/T2	CP/RL2	00000000b
T2MOD	C9H	Timer2 Operating Mode Register	-	-	-	-	-	-	T2OE	DCEN	xxxxxx00b
RCAP2L	CAH	Timer2 Reload Low 8 bits	RCAP2L[7: 0]								00000000b
RCAP2H	CBH	Timer2 Reload High 8 bits	RCAP2H[7: 0]								00000000b
TL2	CCH	Timer2 Low 8 bits	TL2[7: 0]								00000000b
TH2	CDH	Timer2 High 8 bits	TH2[7: 0]								00000000b
BTMCON	CEH	Low-Frequency Timer Control Register	ENBTM	BTMIF	-	-	BTMFS[3: 0]				00xx0000b
WDTCON	CFH	WDT Control Register	-	-	-	CLRWDT	-	WDTCKS[2: 0]			xxx0x000b
PSW	D0H	Program Status Word Register	CY	AC	F0	RS1	RS0	OV	F1	P	00000000b
PWMCFG	D1H	PWM Setup Register	PWMCKS[1: 0]		INV5	INV4	INV3	INV2	INV1	INV0	00000000b
PWMCON	D2H	PWM Control Register	ENPWM	PWMIF	ENPWM5	ENPWM4	ENPWM3	ENPWM2	ENPWM1	ENPWM0	00000000b
PWMPRD	D3H	PWM Period Setting Register	PWMPRD[9: 2]								00000000b
PWMDTYA	D4H	PWM0 duty cycle setting register A	PWMPRD[1: 0]		PDT2[1: 0]		PDT1[1: 0]		PDT0[1: 0]		00000000b
PWMDTY0	D5H	PWM0 duty cycle setting register	PDT0[9: 2]								00000000b
PWMDTY1	D6H	PWM1 duty cycle setting register	PDT1[9: 2]								00000000b
PWMDTY2	D7H	PWM2 duty cycle setting register	PDT2[9: 2]								00000000b
P5	D8H	P5 Data Register	-	-	-	-	-	-	P51	P50	xxxxxx00b
P5CON	D9H	P5 I/O Control Register	-	-	-	-	-	-	P5C1	P5C0	xxxxxx00b
P5PH	DAH	P5 Pull-up Resistor Control Register	-	-	-	-	-	-	P5H1	P5H0	xxxxxx00b

PWMDTYB	DCH	PWM duty cycle setting register B	PWMMOD	-	PDT5[1: 0]	PDT4[1: 0]	PDT3[1: 0]			0x000000b
PWMDTY3	DDH	PWM3 duty cycle setting register / PWM Dead-time Configuration Register	PDT3[9: 2]							0000000b
PWMDTY4	DEH	PWM4 duty cycle setting register	PDT4[9: 2]							0000000b
PWMDTY5	DFH	PWM5 duty cycle setting register	PDT5[9: 2]							0000000b
ACC	E0H	Accumulator	ACC[7: 0]							0000000b
EXA0	E9H	Extended Accumulator 0	EXA[7: 0]							0000000b
EXA1	EAH	Extended Accumulator 1	EXA[15: 8]							0000000b
EXA2	EBH	Extended Accumulator 2	EXA[23: 16]							0000000b
EXA3	ECH	Extended Accumulator 3	EXA[31: 24]							0000000b
EXBL	EDH	Extended B Register L	EXB [7: 0]							0000000b
EXBH	EEH	Extended B Register H	EXB [15: 8]							0000000b
OPERCON	EFH	Arithmetic Control Register	OPERS	MD	-	-	-	-	CHKSUMS	00xxxx0b
B	F0H	B Register	B[7: 0]							0000000b
IAPKEY	F1H	IAP Protection Register	IAPKEY[7: 0]							0000000b
IAPADL	F2H	IAP Address Low byte Register	IAPADR[7: 0]							0000000b
IAPADH	F3H	IAP Address High byte Register	-	-	IAPADR[13: 8]				xx00000b	
IAPADE	F4H	IAP Extended Address Register	IAPADER[7: 0]							0000000b
IAPDAT	F5H	IAP Data Register	IAPDAT[7: 0]							0000000b
IAPCTL	F6H	IAP Control Register	-	-	-	-	PAYTIMES[1: 0]	CMD[1: 0]	xxxx000b	
EXADH	F7H	External SRAM Operating Address High	-	-	-	-	-	EXADH [1: 0]	xxxxx00b	

CHKSUML	FCH	Check Sum Result Register Low	CHKSUML[7: 0]	00000000b
CHKSUMH	FDH	Check Sum Result Register High	CHKSUMH[7: 0]	00000000b
OPINX	FEH	Option Pointer	OPINX[7: 0]	00000000b
OPREG	FFH	Option Register	OPREG[7: 0]	nnnnnnnbn

6.2.1 C51 Core SFRs

Program Counter (PC)

PC does not belong to SFR. 16-bit PC is the register used to control instruction execution sequence. After power-on or reset of microcontroller unit, PC value is 0000H, that is to say, the microcontroller unit is to execute program from 0000H.

Accumulator ACC (E0H)

Accumulator ACC is one of the commonly-used registers in 8051-based microcontroller unit, using A as mnemonic symbol in the instruction system. It is usually used to store operand and results for calculation or logical operations.

B Register (F0H)

B Register shall be used together with Accumulator A in multiplication and division operations. For example, instruction "MUL A, B" is used to multiply 8-bit unsigned numbers of Accumulator A and Register B. As for the acquired 16-bit product, low byte is placed in A and High byte in B. As for "DIV A, B" is used to divide A by B, place integer quotient in A and remainder in B. Register B can also be used as common temporary register.

Stack Pointer SP (81H)

Stack pointer is an 8-bit specialized register, it indicates the address of top stack in common RAM. After resetting of microcontroller unit, the initial value of SP is 07H, and the stack will increase from 08H. 08H ~ 1FH is address of register banks 1 ~ 3.

PSW (D0H) Program Status Word Register (Read/Write)

Bit Number	7	6	5	4	3	2	1	0
Bit Mnemonic	CY	AC	F0	RS1	RS0	OV	F1	P
R/W	R/W	R/W	R/W	R/W	R/W	R/W	R/W	R/W
POR	0	0	0	0	0	0	0	0

Bit Number	Bit Mnemonic	Description															
7	CY	Carry Flag bit 1: The top digit of add operation has carry bit or the top digit of subtraction operation has the borrow digit 0: The top digit of add operation has no carry bit or the top digit of subtraction operation has no borrow digit															
6	AC	Carry-bit auxiliary flag bit (adjustable upon BCD code add and subtraction operations) 1: There is carry bit in bit 3 upon add operation and borrow bit in bit 3 upon subtraction operation 0: No borrow bit and carry bit															
5	F0	User flag bit															
4 ~ 3	RS1、RS0	Register banks selection bits <table border="1" style="margin-left: auto; margin-right: auto;"> <thead> <tr> <th>RS1</th> <th>RS0</th> <th>Current Selected Register banks 0 ~ 3</th> </tr> </thead> <tbody> <tr> <td>0</td> <td>0</td> <td>Group 0 (00H ~ 07H)</td> </tr> <tr> <td>0</td> <td>1</td> <td>Group 1 (08H ~ 0FH)</td> </tr> <tr> <td>1</td> <td>0</td> <td>Group 2 (10H ~ 17H)</td> </tr> <tr> <td>1</td> <td>1</td> <td>Group 3 (18H ~ 1FH)</td> </tr> </tbody> </table>	RS1	RS0	Current Selected Register banks 0 ~ 3	0	0	Group 0 (00H ~ 07H)	0	1	Group 1 (08H ~ 0FH)	1	0	Group 2 (10H ~ 17H)	1	1	Group 3 (18H ~ 1FH)
RS1	RS0	Current Selected Register banks 0 ~ 3															
0	0	Group 0 (00H ~ 07H)															
0	1	Group 1 (08H ~ 0FH)															
1	0	Group 2 (10H ~ 17H)															
1	1	Group 3 (18H ~ 1FH)															
2	OV	Overflow flag bit															
1	F1	F1 flag bit User customized flag															
0	P	Parity flag bit. This flag bit is the parity value of the number of 1 in accumulator ACC. 1: Odd number of number of 1 in ACC 0: Even number of number of 1 in ACC (including 0)															

Data Pointer DPTR (82H, 83H)

The Data pointer DPTR is a 16-bit dedicated register, which is composed of Low byte DPL (82H) and High byte DPH (83H). DPTR is the only register in the traditional 8051-based MCU that can directly conduct 16-bit operation, which can also conduct operations on DPL and DPH by byte.

7 Power, Reset and System Clock

7.1 Power Circuit

The SC92F846XB Power includes circuits such as BG, LDO, POR and LVR, which are able to reliably work within the scope of 2.4V ~ 5.5V. Besides, a calibrated 2.4V voltage is built in the IC, which is used as ADC internal reference voltage. The user can search for specific configuration contents in [18 Analog-to-digital converter \(ADC\)](#).

7.2 Power-on Reset

After the SC92F846XB power-on, the processes carried out before execution of client software are as follows:

- Reset stage
- Loading information stage
- Normal operation stage

7.2.1 Reset Stage

The SC92F846XB will always be in reset mode. There will not be a valid clock until the voltage supplied to the SC92F846XB is higher than certain voltage. The duration of reset stage is related to rising speed of external power. Once the external supply voltage is up to built-in POR voltage, the reset stage would be completed.

7.2.2 Loading Information Stage

There is a preheating counter inside the SC92F846XB. During the reset stage, this preheating counter is always reset as zero. After the voltage is higher than POR voltage, internal RC oscillator starts to oscillate and this preheating counter starts to count. When internal preheating counter counts up to certain number, one byte data will be read from IFB of Flash ROM (including Code Option) for every certain number of HRC clock, which is saved to internal system registers. After the preheating is completed, such reset signal will end.

7.2.3 Normal Operating Stage

After the loading information stage has been completed, the SC92F846XB starts to read instruction code from Flash and enters normal operating stage. At this time, LVR voltage is the set value of Code Option written by user.

7.3 Reset Modes

The SC92F846XB has 4 kinds of reset modes: ① External RST reset ② Low-voltage reset (LVR) ③ Power-on reset (POR) ④ Watchdog (WDT) reset.

7.3.1 External Reset

External reset is to supply a certain width reset pulse signal to the SC92F846XB from the RST pin to realize the SC92F846XB reset.

User can configure P1.1 pin as RST (reset pin) in Customer Option via PC program software before programming.

7.3.2 Low-voltage Reset (LVR)

The SC92F846XB provides a low-voltage reset circuit. There are 4-level LVR voltage options: 4.3V, 3.7V, 2.9V and 2.3V. The default is the Option value written by user.

OP_CTM0 (C1H@FFH) Customer Option Register 0 (Read/Write)

Bit Number	7	6	5	4	3	2	1	0
Bit Mnemonic	ENWDT	ENXTL	SCLKS[1: 0]		DISRST	DISLVR	LVRS[1: 0]	
R/W	R/W	R/W	R/W		R/W	R/W	R/W	
POR	n	n	n		n	n	n	

Bit Number	Bit Mnemonic	Description
2	DISLVR	LVR control bit 0: LVR valid 1: LVR invalid
1 ~ 0	LVRS [1: 0]	LVR voltage selection bits 11: 4.3 V reset 10: 3.7 V reset 01: 2.9 V reset 00: 2.3 V reset

The Circuit Diagram of the SC92F846XB Resetting Part is shown below:

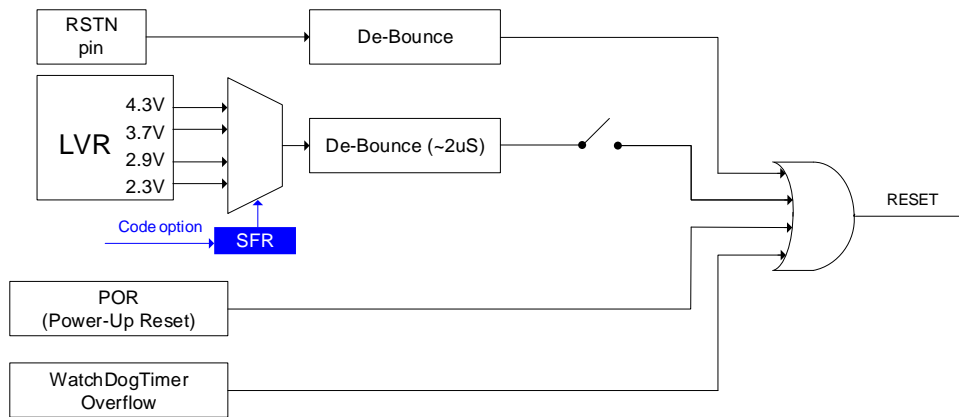

The SC92F846XB Reset Diagram

7.3.3 Power-on Reset (POR)

The SC92F846XB provides a power-on reset circuit. When power voltage V_{DD} is up to POR reset voltage, the system will be reset automatically.

7.3.4 Watchdog Reset (WDT)

The SC92F846XB has a WDT, the clock source of which is the internal 128 kHz oscillator. User can select whether to enable Watchdog Reset function by programmer Code Option.

OP_CTM0 (C1H@FFH) Customer Option Register 0 (Read/Write)

Bit Number	7	6	5	4	3	2	1	0
Bit Mnemonic	ENWDT	ENXTL	SCLKS[1: 0]		DISRST	DISLVR	LVRS[1: 0]	
R/W	R/W	R/W	R/W		R/W	R/W	R/W	
POR	n	n	n		n	n	n	

Bit Number	Bit Mnemonic	Description
7	ENWDT	WDT control bit (This bit is transferred by the system to the value set by the user Code Option) 1: WDT valid 0: WDT invalid

WDTCON (CFH) WDT Control Register (Read/Write)

Bit Number	7	6	5	4	3	2	1	0
Bit Mnemonic	-	-	-	CLRWDT	-	WDTCKS[2: 0]		
R/W	-	-	-	R/W	-	R/W		
POR	x	x	x	0	x	0	0	0

Bit Number	Bit Mnemonic	Description																		
4	CLRWDT	Clear WDT (Only valid when set to 1) 1: WDT counter restart, cleared by system hardware																		
2 ~ 0	WDTCKS [2: 0]	WDT clock selection bits <table border="1" data-bbox="614 1146 1182 2011"> <thead> <tr> <th>WDTCKS[2: 0]</th> <th>WDT overflow time</th> </tr> </thead> <tbody> <tr> <td>000</td> <td>500ms</td> </tr> <tr> <td>001</td> <td>250ms</td> </tr> <tr> <td>010</td> <td>125ms</td> </tr> <tr> <td>011</td> <td>62.5ms</td> </tr> <tr> <td>100</td> <td>31.5ms</td> </tr> <tr> <td>101</td> <td>15.75ms</td> </tr> <tr> <td>110</td> <td>7.88ms</td> </tr> <tr> <td>111</td> <td>3.94ms</td> </tr> </tbody> </table>	WDTCKS[2: 0]	WDT overflow time	000	500ms	001	250ms	010	125ms	011	62.5ms	100	31.5ms	101	15.75ms	110	7.88ms	111	3.94ms
WDTCKS[2: 0]	WDT overflow time																			
000	500ms																			
001	250ms																			
010	125ms																			
011	62.5ms																			
100	31.5ms																			
101	15.75ms																			
110	7.88ms																			
111	3.94ms																			
7 ~ 5, 3	-	Reserved																		

7.3.5 Register Reset Value

During reset, most registers are set to their initial values and the WDT remains disable. The register of PORT is FFh. The initial value of program counter (PC) is 0000h, and the initial value of stack pointer SP is 07h. Reset of “Hot Start” (such as WDT, LVR, etc.) will not influence SRAM which always keep the value before resetting. The SRAM contents will be retained until the power voltage is too low to keep RAM alive.

The initial value of power-on reset in SFRs is shown in the table below:

Mnemonic	Reset value	Mnemonic	Reset value
ACC	0000000z0b	P1PH	00000000b
B	00000000b	P2	00000000b
PSW	00000000b	P2CON	00000000b
SP	00000111b	P2PH	00000000b
DPL	00000000b	P5	xxxxxx00b
DPH	00000000b	P5CON	xxxxxx00b
PCON	0xxxxx00b	P5PH	xxxxxx00b
ADCCFG0	00000000b	PWMCFG	00000000b
ADCCFG1	xxxxxx00b	PWMCON	00000000b
ADCCFG2	xxxx0000b	PWMDTYA	xx000000b
ADCCON	00000000b	PWMDTY0	00000000b
ADCVH	00000000b	PWMDTY1	00000000b
ADCVL	0000xxxxb	PWMDTY2	00000000b
BTMCON	00xx0000b	PWMPRD	00000000b
IAPADE	00000000b	PWMDTYB	0x000000b

IAPADH	xx000000b	PWMDTY3	00000000b
IAPADL	00000000b	PWMDTY4	00000000b
IAPCTL	xxxx0000b	PWMDTY5	00000000b
IAPDAT	00000000b	RCAP2H	00000000b
IAPKEY	00000000b	RCAP2L	00000000b
IE	00000000b	SBUF	00000000b
IE1	xxx00000b	SCON	00000000b
INT0R	xxxx000xb	SSDAT	00000000b
INT1R	xxxx0000b	SSCON0	00000000b
INT2R	xx000000b	SSCON1	00000000b
INT0F	xxxx000xb	SSCON2	00000000b
INT1F	xxxx0000b	TCON	0000x0xb
INT2F	xx000000b	TMCON	xxxxx000b
IP	x0000000b	TMOD	x000x000b
IP1	xxx00000b	TH0	00000000b
OPINX	00000000b	TL0	00000000b
OPREG	nnnnnnnnb	TH1	00000000b
EXADH	xxxxxx00b	TL1	00000000b
OTCON	00xx00xxb	T2CON	00000000b

IOHCON	00000000b	TH2	00000000b
P0	00000000b	TL2	00000000b
P0CON	00000000b	T2MOD	xxxxxx00b
P0PH	00000000b	WDTCN	xxx0x000b
P0VO	xx000000b	CHKSUMH	00000000b
P1	00000000b	CHKSUML	00000000b
P1CON	00000000b	-	-

7.4 High-speed RC Oscillator

The SC92F846XB has a built-in adjustable high-precision HRC and a crystal oscillation circuit. The user can choose either as the system clock. HRC is precisely calibrated to 24 MHz@5V/25°C when delivery. The user can set system clock as 12/6/2MHz by programmer Code Option. The calibration process is to filter the influence of processing deviation on precision. There will be certain drifting of this HRC depending on operating temperature and voltage. As for voltage drifting (3.0V ~ 5.5V) and temperature drifting (-20°C ~ 85°C), the deviation is within ±1%.

In order to enhance the reliability of the system, the SC92F846XB has a system clock monitoring circuit built in. When user chooses the crystal oscillation as system clock source and the crystal oscillation circuit stops oscillating, the system clock source will be automatically switched to the built-in HRC, and this state will be maintained until the next reset.

Note: The clock source of ADC and dual mode TouchKey circuit is $f_{HRC} = 24\text{MHz}$, which is independent of switch of system clock.

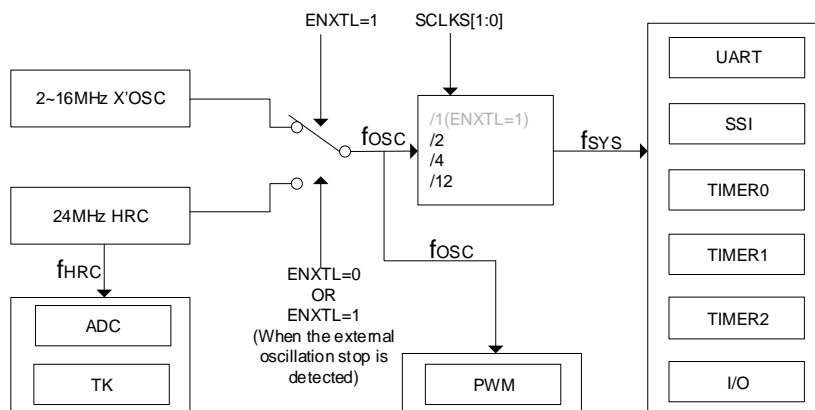

The SC92F846XB Internal Clock Relationship

OP_CTM0 (C1H@FFH) Customer Option Register 0 (Read/Write)

Bit Number	7	6	5	4	3	2	1	0
Bit Mnemonic	ENWDT	ENXTL	SCLKS[1: 0]		DISRST	DISLVR	LVRS[1: 0]	
R/W	R/W	R/W	R/W		R/W	R/W	R/W	
POR	n	n	n		n	n	n	

Bit Number	Bit Mnemonic	Description
6	ENXTL	<p>External high-frequency crystal oscillator selection bit</p> <p>0: external high-frequency crystal Interface disable, P5.0 and P5.1 valid</p> <p>1: external high-frequency crystal Interface enable, P5.0 and P5.1 invalid</p> <p>Note: The clock source of ADC and dual mode TouchKey circuit is $f_{HRC} = 24\text{MHz}$, which is independent of switch of system clock.</p>
5 ~ 4	SCLKS[1: 0]	<p>System clock frequency selection bits:</p> <p>00: reserved; System clock frequency is HRC frequency divided by 1, only valid when ENXTL=0;</p> <p>01: system clock frequency is HRC frequency divided by 2;</p> <p>10: system clock frequency is HRC frequency divided by 4;</p> <p>11: system clock frequency is HRC frequency divided by 12;</p>

OP_CTM1 (C2h@FFH) Customer Option Register 1 (Read/Write)

Bit Number	7	6	5	4	3	2	1	0
Bit Mnemonic	VREFS	XTLHF	-	-	IAPS[1: 0]		-	-

R/W	R/W	R/W	-	-	R/W	R/W	-	-
POR	n	n	x	x	n	n	x	x

Bit Number	Bit Mnemonic	Description
6	XTLHF	External clock source frequency mode register selection bit 0: Match with the external clock source which frequency <12M 1: Match with the external clock source which frequency ≥12M

The SC92F846XB has a special function: the user can modify SFR value to adjust frequency of HRC within certain scope. User can realize this operation by configuring OP_HRCR register. For configuration method of this register, refer to [5.2.1 Customer-Option-related Registers Operation Instructions](#).

OP_HRCR (83h@FFH) System Clock Change Register (Read/Write)

Bit Number	7	6	5	4	3	2	1	0
Bit Mnemonic	OP_HRCR[7: 0]							
R/W	R/W							
POR	n	n	n	n	n	n	n	n

Bit Number	Bit Mnemonic	Description
7 ~ 0	OP_HRCR[7: 0]	HRC frequency change register User can change high-frequency oscillator frequency f_{HRC} by modifying the value of this register, and then change the IC system clock frequency f_{SYS} : 1. Initial value OP_HRCR[s] after OP_HRCR[7: 0] power-on is a fixed value, which guarantee f_{HRC} is 24MHz, there may be difference in OP_HRCR[s] of each IC

		<p>2. When initial value is OP_HRCR[s], IC system clock frequency f_{SYS} can set specifically as 12/6/2MHz by Option. For each change of 1 for OP_HRCR [7: 0], the change of f_{SYS} frequency is about 0.23%.</p> <p>The relationship between OP_HRCR [7: 0] and output frequency f_{SYS} is shown as follows:</p> <table border="1" data-bbox="614 470 1444 1489"> <tr> <td>OP_HRCR [7:0]</td> <td>f_{SYS} actual output frequency (taking 12M as an example)</td> </tr> <tr> <td>OP_HRCR [s]-n</td> <td>$12000 * (1 - 0.23\% * n)$ kHz</td> </tr> <tr> <td>...</td> <td>....</td> </tr> <tr> <td>OP_HRCR [s]-2</td> <td>$12000 * (1 - 0.23\% * 2) = 11944.8$ kHz</td> </tr> <tr> <td>OP_HRCR [s]-1</td> <td>$12000 * (1 - 0.23\% * 1) = 11972.4$ kHz</td> </tr> <tr> <td>OP_HRCR [s]</td> <td>12000 kHz</td> </tr> <tr> <td>OP_HRCR [s]+1</td> <td>$12000 * (1 + 0.23\% * 1) = 12027.6$ kHz</td> </tr> <tr> <td>OP_HRCR [s]+2</td> <td>$12000 * (1 + 0.23\% * 2) = 12055.2$ kHz</td> </tr> <tr> <td>...</td> <td>...</td> </tr> <tr> <td>OP_HRCR [s]+n</td> <td>$12000 * (1 + 0.23\% * n)$ kHz</td> </tr> </table> <p>Notes:</p> <ol style="list-style-type: none"> The value of OP_HRCR[7:0] after each power-on of the IC is the value of high-frequency oscillator frequency f_{HRC} closest to 24MHz; the user can modify the value of HRC after each power-on by means of EEPROM to make IC system clock frequency f_{SYS} work at the frequency the user needs. To guarantee IC operating reliably, the maximum operating frequency of IC shall not exceed 10% of 12MHz, which is 13.2MHz; The user shall confirm the change of HRC frequency will not influence other functions. 	OP_HRCR [7:0]	f_{SYS} actual output frequency (taking 12M as an example)	OP_HRCR [s]-n	$12000 * (1 - 0.23\% * n)$ kHz	OP_HRCR [s]-2	$12000 * (1 - 0.23\% * 2) = 11944.8$ kHz	OP_HRCR [s]-1	$12000 * (1 - 0.23\% * 1) = 11972.4$ kHz	OP_HRCR [s]	12000 kHz	OP_HRCR [s]+1	$12000 * (1 + 0.23\% * 1) = 12027.6$ kHz	OP_HRCR [s]+2	$12000 * (1 + 0.23\% * 2) = 12055.2$ kHz	OP_HRCR [s]+n	$12000 * (1 + 0.23\% * n)$ kHz
OP_HRCR [7:0]	f_{SYS} actual output frequency (taking 12M as an example)																					
OP_HRCR [s]-n	$12000 * (1 - 0.23\% * n)$ kHz																					
...																					
OP_HRCR [s]-2	$12000 * (1 - 0.23\% * 2) = 11944.8$ kHz																					
OP_HRCR [s]-1	$12000 * (1 - 0.23\% * 1) = 11972.4$ kHz																					
OP_HRCR [s]	12000 kHz																					
OP_HRCR [s]+1	$12000 * (1 + 0.23\% * 1) = 12027.6$ kHz																					
OP_HRCR [s]+2	$12000 * (1 + 0.23\% * 2) = 12055.2$ kHz																					
...	...																					
OP_HRCR [s]+n	$12000 * (1 + 0.23\% * n)$ kHz																					

7.5 Low-speed RC Oscillator

The SC92F846XB is equipped with a built-in 128kHz RC oscillation circuit, which can be set as clock source of low-frequency clock timer Base Timer and WDT.

Base Timer, a low-frequency clock timer which can wake up CPU from STOP mode and generate interrupt.

BTMCON (CEH) Low-Frequency Timer Control Register (Read/Write)

Bit Number	7	6	5	4	3	2	1	0
Bit Mnemonic	ENBTM	BTMIF	-	-	BTMFS[3: 0]			
R/W	R/W	R/W	-	-	R/W			
POR	0	0	x	x	0	0	0	0

Bit Number	Bit Mnemonic	Description
7	ENBTM	Low-frequency Base Timer start control bit 0: Base Timer not start 1: Base Timer start
6	BTMIF	Base Timer interrupt application flag bit When CPU receives Base Timer interrupt, this flag will be cleared automatically by hardware.
3 ~ 0	BTMFS [3: 0]	Low-frequency clock interrupt frequency selection bits 0000: an interrupt is generated for every 15.625ms 0001: an interrupt is generated for every 31.25ms 0010: an interrupt is generated for every 62.5ms 0011: an interrupt is generated for every 125ms 0100: an interrupt is generated for every 0.25s 0101: an interrupt is generated for every 0.5s 0110: an interrupt is generated for every 1.0s

		0111: an interrupt is generated for every 2.0s 1000: an interrupt is generated for every 4.0s 1001 ~ 1111: reserved
5 ~ 4	-	Reserved

7.6 Power Saving Modes

The SC92F846XB provides a SFR PCON, the user can configure bit 0 and bit 1 of this register to control MCU to enter different operating modes.

When PCON.1 = 1, internal high-frequency system clock would stop and system enter STOP mode, to save power. The system can be woken up from STOP by external interrupt INT0 ~ INT2, low-frequency clock interrupt, TK interrupt, and external reset input.

When PCON.0 = 1, the program would stop running and System enter IDLE mode. But the external equipment and clock will continue running, CPU will keep all states before entering IDLE mode. The system can be woken up from IDLE by any interrupt.

PCON (87H) Power Management Control Register (only for write, *unreadable*)

Bit Number	7	6	5	4	3	2	1	0
Bit Mnemonic	SMOD	-	-	-	-	-	STOP	IDL
R/W	W	-	-	-	-	-	W	W
POR	0	x	x	x	x	x	0	0

Bit Number	Bit Mnemonic	Description
1	STOP	STOP mode control bit 0: normal operating mode 1: stop mode, high-frequency oscillator stops operating, low-frequency oscillator and WDT can select to work based on configuration
0	IDL	IDLE mode control bit

		0: normal operating mode 1: IDLE mode, the program stops operating, but external equipment and clock continue to operate and all CPU states are saved before entering IDLE mode
--	--	--

Notes: When Configure MCU to enter STOP or IDLE mode, the instruction of configuring PCON register should be followed by 8 “NOP” instructions rather than other instructions. Or else, it will be unable to execute following instructions normally after wake-up!

For example, configure MCU to enter STOP mode:

C program example:

```
#include"intrins.h"

PCON |= 0x02;          //Set to 1 for PCON bit1 STOP bit, configure MCU to enter STOP mode

_nop_ ();             //At least 8 _nop_ () required

_nop_ ();

_nop_ ();

_nop_ ();

_nop_ ();

_nop_ ();

_nop_ ();

.....
```

Assembly program example:

```
ORL PCON, #02H      ; Set to 1 for PCON bits1 STOP bit, configure MCU to enter STOP mode

NOP                 ; At least 8 NOP required

NOP

NOP

NOP

NOP

NOP

NOP

NOP

.....
```

8 CPU and Function System

8.1 CPU

CPU used by the SC92F846XB is the high-speed 1T standard 8051 core, whose instructions are completely compatible with traditional 8051 core microcontroller unit.

8.2 Addressing Mode

The addressing mode of the SC92F846XB 1T 8051 CPU instructions includes: ① Immediate Addressing ② Direct Addressing ③ Indirect Addressing ④ Register Addressing ⑤ Relative Addressing ⑥ Indexed Addressing ⑦ Bit Addressing

8.2.1 Immediate Addressing

Immediate addressing is also called immediate operand addressing, which is the operand given to participate in operation in instruction, the instruction is illustrated as follows:

MOV A, #50H (This instruction is to move immediate operand 50H to Accumulator A)

8.2.2 Direct Addressing

In direct addressing mode, the instruction operand field indicates the address to participate in operation operand. Direct addressing can only be used to address SFRs, internal data registers and bit address space. The SFRs and bit address space can only be accessed by direct addressing. For example:

ANL 50H, #91H (The instruction indicates the data in 50H unit AND immediate operand 91H, and the results are stored in 50H unit. 50H refers to direct address, indicating one unit in internal data register RAM.)

8.2.3 Indirect Addressing

Indirect addressing is expressed as adding "@" before R0 or R1. Suppose the data in R1 is 40H and the data of internal data register 40H unit is 55H, then the instruction will be

MOV A, @R1 (Move the data 55h to Accumulator A).

8.2.4 Register Addressing

Register addressing is to operate the data in the selected registers R7 ~ R0, Accumulator A, general-purpose register B, address registers and carry bit C. The registers R7-R0 is indicated by lower 3 bits of instruction code. ACC, B, DPTR and carry bit C are implied in the instruction code. Therefore, register addressing can also include an implied addressing mode. The selection of register operating area depends on RS1 and RS0 of PSW. The registers indicated by instruction operand refers to the registers in current operating area.

INC R0 refers to (R0) +1 → R0

8.2.5 Relative Addressing

Relative addressing is to add current value in program counter (PC) and the data in the second byte of the

instruction, whose result shall be taken as the jump address of jump instruction. The Jump address is the target jump address, the current value in PC is the base address and the data in the second byte of the instruction is the offset address. Because the target jump address is relative to base address in PC, such addressing mode is called relative addressing. The offset is signed number, which ranges from +127 to -128, such addressing mode is mainly applied to jump instruction.

```
JC    $ +50H
```

It indicates that if the carry bit C is 0, the contents in program counter PC remain the same, meaning no jump. On the contrary, if the carry bit C is 1, take the sum of the current value in PC and base address as well as offset 50H as the target jump address of this jump instruction.

8.2.6 Indexed Addressing

In indexed addressing mode, the instruction operand is to develop an indexed register to store indexed base address. Upon indexed addressing, the result by adding offset and indexed base address is taken as the address of operation operand. The indexed registers include PC and address register DPTR.

```
MOVC  A, @A+DPTR
```

It indicates Accumulator A is used as offset register. Take the sum of the value in A and that in the address register DPTR as the address of operand. Then take the figure in the address out and transmit it to Accumulator A.

8.2.7 Bits Addressing

Bit addressing is a kind of addressing mode when conducting bit operation on internal data storage RAM and SFRs which are able to carry out bit operations. Upon bit operations, by taking carry bit C as bit operation accumulator, the instruction operand will give the address of this bit directly, then execute bit operation based on the nature of operation code.

```
MOV  C, 20H (Transmit the bit operation register with address of 20H into carry bit C)
```

9 Interrupt

The SC92F846XB provides 12 interrupt sources: Timer0, Timer1, Timer2, INT0 ~ 2, ADC, PWM, UART, SSI, Base Timer and TK. These 12 interrupt sources are equipped with 2-level interrupt priority capability and each interrupt source can be individually configured in high priority or low priority. As for three external interrupts, the triggering condition of each interrupt source can be set as rising edge, falling edge or dual-edge trigger. Each interrupt is equipped with independent priority setting bit, interrupt flag, interrupt vector and enable bit. Global interrupt enable bit EA can enable or disable all interrupts.

9.1 Interrupt Source and Vector

Lists for the SC92F846XB interrupt source, interrupt vector and related control bit are shown below:

Interrupt Source	Interrupt condition	Interrupt Flag	Interrupt Enable Control	Interrupt Priority Control	Interrupt Vector	Query Priority	Interrupt Number (C51)	Flag Clear Mode	Capability of Waking up STOP
INT0	Compliant with External interrupt 0 conditions	IE0	EINT0	IPINT0	0003H	1 (high)	0	H/W Auto	Yes
Timer0	Timer0 overflow	TF0	ET0	IPT0	000BH	2	1	H/W Auto	No
INT1	Compliant with External interrupt 1 conditions	IE1	EINT1	IPINT1	0013H	3	2	H/W Auto	Yes
Timer1	Timer1 overflow	TF1	ET1	IPT1	001BH	4	3	H/W Auto	No
UART	Receiving or transmitting completed	RI/TI	EUART	IPUART	0023H	5	4	Must be cleared by user	No
Timer2	Timer2 overflow	TF2	ET2	IPT2	002BH	6	5	Must be cleared by user	No
ADC	ADC conversion completed	ADCIF	EADC	IPADC	0033H	7	6	Must be cleared by user	No
SSI	Receiving or transmitting completed	SPIF/TWIF	ESSI	IPSPI	003BH	8	7	Must be cleared by user	No
PWM	PWM overflow	PWMIF	EPWM	IPPWM	0043H	9	8	H/W Auto	No
BTM	Base timer overflow	BTMIF	EBTM	IPBTM	004BH	10	9	H/W Auto	Yes

INT2	External interrupt 2 conditions compliant	-	EINT2	IPINT2	0053H	11	10	-	Yes
TK	TouchKey counter overflow	TKIF	ETK	IPTK	005B	12	11	H/W Auto	No

Under the circumstance where the master interrupt control bit EA and the respective interrupt control bit have been enable, the interrupt occurrence is shown below:

Timer Interrupt: Interrupt generates when Timer0 or Timer1 overflows and the interrupt flag TF0 or TF1 is set to “1”. When the microcontroller unit responds to the timer interrupt, the interrupt flag TF0 or TF1 is reset automatically by hardware. Interrupt generates when Timer2 overflows and the interrupt flag TF2 is set to “1”. Once Timer2 interrupt generates, the hardware would not automatically clear TF2 bit, which must be cleared by the user’s software.

ADC Interrupt: After ADC conversion is completed, ADC interrupt generates, whose interrupt flag is the ADC conversion completion flag EOC/ADCIF (ADCCON.5). When user starts ADCS conversion, EOC will be reset automatically by hardware. Once conversion completes, EOC would be set to “1” automatically by hardware. User should clear the ADC interrupt flag by software when the interrupt service routine is executed after ADC interrupt generates.

SSI Interrupt: When SSI completes receiving or transmitting a frame of data, SPIF/TWIF bit will be set to “1” automatically by hardware, and SSI interrupt generates. When the microcontroller unit serves SSI interrupt, the interrupt flag SPIF/TWIF must be cleared by software.

PWM Interrupt: When PWM counter overflows (beyond PWMPD), The PWMIF bit will be set to 1 automatically by hardware, PWM interrupt generates. When the microcontroller unit executes PWM interrupt, the interrupt sign PWMIF will be clear to “0” automatically by hardware.

External Interrupt INT0 ~ 2: When any external interrupt pin meets the interrupt conditions, external interrupt generates. There are 3 external interrupt sources for INT0, 4 external interrupt sources for INT1 and 6 external interrupt sources for INT2, which can be set in rising edge, falling edge or dual edge interrupt trigger mode by setting SFRs (INTxF and INTxR). User can set the priority level of each interrupt through IP register. Besides, external interrupt INT0 ~ 2 can also wake up STOP mode of microcontroller unit.

9.2 Interrupt Structure Diagram

The SC92F846XB interrupt structure is shown in the figure below:

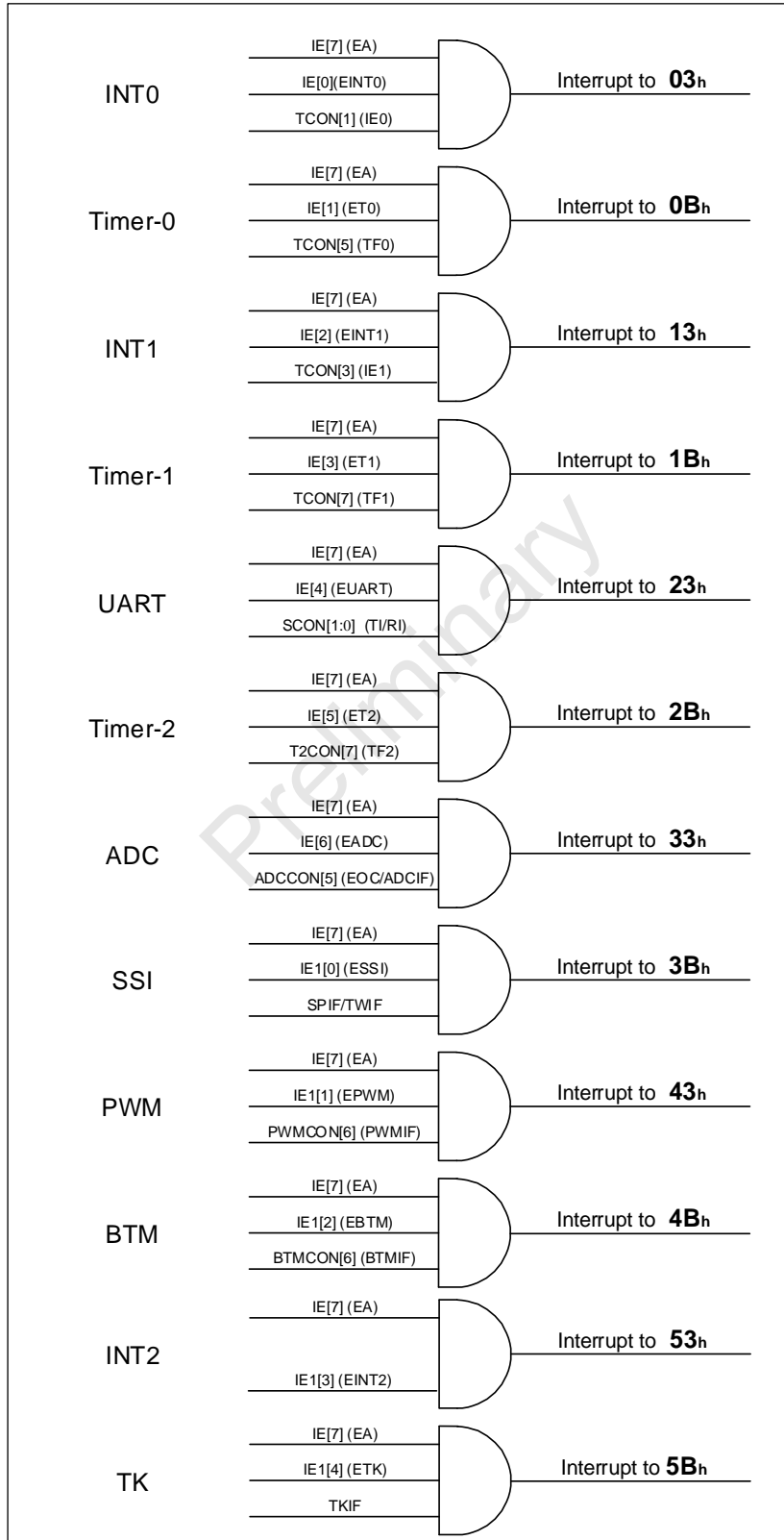

The SC92F846XB Interrupt Structure and Vector

9.3 Interrupt Priority

The SC92F846XB microcontroller unit has two-level interrupt priority capability. The interrupt requests of these interrupt sources can be programmed as high-priority interrupt or low-priority interrupt, which is to realize the nesting of two levels of interrupt service programs. One interrupt can be interrupted by a higher priority interrupt request when being responded to, which can not be interrupted by another interrupt request at the same priority level, until such response to the first-come interrupt ends up with the instruction “RETI”. Exist the interrupt service routine and return to main program, the system would execute one more instruction before responding to new interrupt request.

That is to say:

- ① A lower priority interrupt can be interrupted by a higher priority interrupt request, but not vice versa;
- ② Any kind of interrupt being responded to can not be interrupted by another interrupt request at the same priority level.

Interrupt query sequence: As for the sequence of that the SC92F846XB microcontroller unit responds to the same priority interrupts which occur in the meantime, the priority sequence of interrupt response shall be the same as the interrupt query number in C51, which is to preferentially respond to the interrupt with smaller query number then the interrupt with bigger query number.

9.4 Interrupt Processing Flow

When any interrupt generates and is responded by CPU, the operation of main program will be interrupted to carry out the following operations:

- ① Complete execution of instruction being currently executed;
- ② Push the PC value into stack for site protection;
- ③ Load Interrupt vector address into program counter (PC);
- ④ Carry out corresponding interrupt service program;
- ⑤ End Interrupt service program ends and execute RETI;
- ⑥ Pop PC value from stack and return to the program before responding to the interrupt.

During this process, the system will not immediately respond to other interrupts at the same priority level, but it will keep all interrupt requests having occurred and respond to new interrupt requests upon completing handling of the current interrupt.

9.5 Interrupt-related Registers

IE (A8H) Interrupt Enable Register (Read/Write)

Bit Number	7	6	5	4	3	2	1	0
-------------------	----------	----------	----------	----------	----------	----------	----------	----------

Bit Mnemonic	EA	EADC	ET2	EUART	ET1	EINT1	ET0	EINT0
R/W	R/W	R/W	R/W	R/W	R/W	R/W	R/W	R/W
POR	0	0	0	0	0	0	0	0

Bit Number	Bit Mnemonic	Description
7	EA	Global interrupt enable control bit 0: Disable all interrupts 1: Enable all interrupts
6	EADC	ADC interrupt enable control bit 0: Disable ADC interrupts 1: Interrupt is allowed upon completing ADC conversion
5	ET2	Timer2 interrupt enable control bit 0: Disable Timer2 interrupt 1: Enable Timer2 interrupt
TONG4	EUART	UART interrupt enable control bit 0: Disable UART interrupt 1: Enable UART interrupt
3	ET1	Timer1 interrupt enable control bit 0: Disable Timer1 interrupt 1: Enable Timer1 interrupt
2	EINT1	External interrupt 1 enable control 0: Disable INT1 interrupt 1: Enable INT1 interrupt

1	ET0	Timer0 interrupt enable control bit 0: Disable Timer0 interrupt 1: Enable Timer0 interrupt
0	EINT0	External interrupt 0 enable control bit 0: Disable INT0 interrupt 1: Enable INT0 interrupt

IP (B8H) Interrupt Priority Control Register (Read/Write)

Bit Number	7	6	5	4	3	2	1	0
Bit Mnemonic	-	IPADC	IPT2	IPUART	IPT1	IPINT1	IPT0	IPINT0
R/W	-	R/W	R/W	R/W	R/W	R/W	R/W	R/W
POR	x	0	0	0	0	0	0	0

Bit Number	Bit Mnemonic	Description
6	IPADC	ADC interrupt priority selection bit 0: ADC interrupt priority is low 1: ADC interrupt priority is high
5	IPT2	Timer2 interrupt priority selection bit 0: Timer2 interrupt priority is low 1: Timer2 interrupt priority is high
4	IPUART	UART interrupt priority selection bit 0: UART interrupt priority is low 1: UART interrupt priority is high

3	IPT1	Timer1 interrupt priority selection bit 0: Timer1 interrupt priority is low 1: Timer1 interrupt priority is high
2	IPINT1	INT1 interrupt priority selection bit 0: INT1 interrupt priority is low 1: INT1 interrupt priority is high
1	IPT0	Timer 0 interrupt priority selection bit 0: Timer0 interrupt priority is low 1: Timer0 interrupt priority is high
0	IPINT0	INT0 interrupt priority selection bit 0: INT0 interrupt priority is low 1: INT0 interrupt priority is high
7	-	Reserved

IE1 (A9H) Interrupt Enable Register 1 (Read/Write)

Bit Number	7	6	5	4	3	2	1	0
Bit Mnemonic	-	-	-	ETK	EINT2	EBTM	EPWM	ESSI
R/W	-	-	-	R/W	R/W	R/W	R/W	R/W
POR	x	x	x	0	0	0	0	0

Bit Number	Bit Mnemonic	Description
4	ETK	TouchKey interrupt enabling control bit 0: Disable TouchKey interrupt

		1: Enable TouchKey interrupt
3	EINT2	External interrupt 2 enabling control bit 0: Disable External interrupt 2 1: Enable External interrupt 2
2	EBTM	Base Timer interrupt enabling control bit 0: Disable Base Timer interrupt 1: Enable Base Timer interrupt
1	EPWM	PWM interrupt enabling control bit 0: Disable PWM interrupt 1: Enable interrupt upon PWM counting overflows (counting to PWMPRD)
0	ESSI	Three-in-on serial interrupt enabling control 0: Disable serial port interrupt 1: Enable serial port interrupt
7 ~ 6	-	Reserved

IP1 (B9H) Interrupt Priority Control Register 1 (Read/Write)

Bit Number	7	6	5	4	3	2	1	0
Bit Mnemonic	-	-	-	IPTK	IPINT2	IPBTM	IPPWM	IPSSI
R/W	-	-	-	R/W	R/W	R/W	R/W	R/W
POR	x	x	x	0	0	0	0	0

Bit Number	Bit Mnemonic	Description
------------	--------------	-------------

4	IPTK	TouchKey interrupt priority selection bit 0: TouchKey interrupt priority is low 1: TouchKey interrupt priority is high
3	IPINT2	INT2 interrupt priority selection bit 0: INT2 interrupt priority is low 1: INT2 interrupt priority is high
2	IPBTM	Base Timer interrupt priority selection bit 0: Base Timer interrupt priority is low 1: Base Timer interrupt priority is high
1	IPPWM	PWM interrupt priority selection bit 0: PWM interrupt priority is low 1: PWM interrupt priority is high
0	IPSSI	Three-in-on serial interrupt priority selection bit 0: SSI interrupt priority is low 1: SSI interrupt priority is high
7 ~ 5	-	Reserved

TCON (88H) Timer Control Register (Read/Write)

Bit Number	7	6	5	4	3	2	1	0
Bit Mnemonic	TF1	TR1	TF0	TR0	IE1	-	IE0	-
R/W	R/W	R/W	R/W	R/W	R/W	-	R/W	-
POR	0	0	0	0	0	x	0	x

Bit Number	Bit Mnemonic	Description
3	IE1	INT1 overflow interrupt request flag bit When INT1 overflow occurs, interrupt generates, hardware set IE1 to "1"; when the application is interrupted, upon CPU responds, the hardware resets it to "0"
1	IE0	INT0 overflow interrupt request flag bit When INT1 overflow occurs, interrupt generates, hardware set IE0 to "1"; when the application is interrupted, upon CPU responds, the hardware resets it to "0"
2, 0	-	Reserved

INT0F (BAH) INT0 Falling Edge Interrupt Control Register (Read/Write)

Bit Number	7	6	5	4	3	2	1	0
Bit Mnemonic	-	-	-	-	INT0F3	INT0F2	INT0F1	-
R/W	-	-	-	-	R/W	R/W	R/W	-
POR	x	x	x	x	0	0	0	x

Bit Number	Bit Mnemonic	Description
3 ~ 1	INT0Fn (n=1 ~ 3)	INT0 falling edge interrupt control bit 0: INT0n falling edge interrupt off 1: INT0n falling edge interrupt enabling
7 ~ 4, 0	-	Reserved

INT0R (BBH) INT0 Rising Edge Interrupt Control Register (Read/Write)

Bit Number	7	6	5	4	3	2	1	0
Bit Mnemonic	-	-	-	-	INT0R3	INT0R2	INT0R1	-
R/W	-	-	-	-	R/W	R/W	R/W	-
POR	x	x	x	x	0	0	0	x

Bit Number	Bit Mnemonic	Description
3 ~ 1	INT0Rn (n=1 ~ 3)	INT0 rising edge interrupt control bit 0: INT0n rising edge interrupt off 1: INT0n rising edge interrupt enabling
7 ~ 4, 0	-	Reserved

INT1F (BCH) INT1 Falling Edge Interrupt Control Register (Read/Write)

Bit Number	7	6	5	4	3	2	1	0
Bit Mnemonic	-	-	-	-	INT1F3	INT1F2	INT1F1	INT1F0
R/W	-	-	-	-	R/W	R/W	R/W	R/W
POR	x	x	x	x	0	0	0	0

Bit Number	Bit Mnemonic	Description
3 ~ 0	INT1Fn (n=0 ~ 3)	INT1 falling edge interrupt control bit 0: INT1n falling edge interrupt off

		1: INT1n falling edge interrupt enabling
7 ~ 4	-	Reserved

INT1R (BDH) INT1 Rising Edge Interrupt Control Register (Read/Write)

Bit Number	7	6	5	4	3	2	1	0
Bit Mnemonic	-	-	-	-	INT1R3	INT1R2	INT1R1	INT1R0
R/W	-	-	-	-	R/W	R/W	R/W	R/W
POR	x	x	x	x	0	0	0	0

Bit Number	Bit Mnemonic	Description
3 ~ 0	INT1Rn (n=0 ~ 3)	INT1 rising edge interrupt control bit 0: INT1n rising edge interrupt off 1: INT1n rising edge interrupt enabling
7 ~ 4	-	Reserved

INT2F (C6H) INT2 Falling Edge Interrupt Control Register (Read/Write)

Bit Number	7	6	5	4	3	2	1	0
Bit Mnemonic	-	-	INT2F5	INT2F4	INT2F3	INT2F2	INT2F1	INT2F0
R/W	-	-	R/W	R/W	R/W	R/W	R/W	R/W
POR	x	x	0	0	0	0	0	0

Bit Number	Bit Mnemonic	Description
5 ~ 0	INT2Fn (n=0 ~ 5)	INT2 falling edge interrupt control bit 0: INT2n falling edge interrupt off 1: INT2n falling edge interrupt enabling
7 ~ 6	-	Reserved

INT2R (C7H) INT2 Rising Edge Interrupt Control Register (Read/Write)

Bit Number	7	6	5	4	3	2	1	0
Bit Mnemonic	-	-	INT2R5	INT2R4	INT2R3	INT2R2	INT2R1	INT2R0
R/W	-	-	R/W	R/W	R/W	R/W	R/W	R/W
POR	x	x	0	0	0	0	0	0

Bit Number	Bit Mnemonic	Description
5 ~ 0	INT2Rn (n=0 ~ 5)	INT2 rising edge interrupt control bit 0: INT2n rising edge interrupt off 1: INT2n rising edge interrupt enabling
7 ~ 6	-	Reserved

10 Timer/Counter T0 and T1

The SC92F846XB has two 16-bit Timer/Counters, Timer0 (T0) and Time1 (T1), with two operating modes: counter mode and timer mode. The operating modes selected by bit C/Tx in the SFR TMOD. T0 and T1 are essentially adding counters with different counting source. The source of timer generated from system clock or frequency division clock, but the source of counters is the input pulse to external pin. Only when TRx = 1, will T0 and T1 be enabled on for counting.

In counter mode, each input pulse on P1.2/T0 and P1.3/T1 pin will make the count value of T0 and T1 increase by 1 respectively.

In timer mode, users can select $f_{sys}/12$ or f_{sys} (f_{sys} is the system clock after frequency division) as counting source of T0 and T1 by configuring SFR TMCON.

Timer/Counter T0 has 4 operating modes, and Timer/Counter T1 has 3 operating modes (Mode 3 does not exist):

- ① Mode 0: 13-bit Timer/Counter mode
- ② Mode 1: 16-bit Timer/Counter mode
- ③ Mode 2: 8-bit automatic reload mode
- ④ Mode 3: Two 8-bit timers/counters mode

In above modes, modes 0, 1 and 2 of T0 and T1 are the same, and mode 3 is different.

10.1 T0 and T1-related Registers

Mnemonic	Add	Description	7	6	5	4	3	2	1	0	POR
TCON	88H	Timer Control Register	TF1	TR1	TF0	TR0	IE1	-	IE0	-	00000x0xb
TMOD	89H	Timer Operating Mode Register	-	C/T1	M11	M01	-	C/T0	M10	M00	x000x000b
TL0	8AH	Timer0 Low byte	TL0[7: 0]								00000000b
TL1	8BH	Timer1 Low byte	TL1[7: 0]								00000000b
TH0	8CH	Timer0 High byte	TH0[7: 0]								00000000b
TH1	8DH	Timer1 High byte	TH1[7: 0]								00000000b
TMCON	8EH	Timer Frequency Control Register	-	-	-	-	-	T2FD	T1FD	T0FD	xxxxx000b

Register instructions are shown below:

TCON (88H) Timer Control Register (Read/Write)

Bit Number	7	6	5	4	3	2	1	0
Bit Mnemonic	TF1	TR1	TF0	TR0	IE1	-	IE0	-
R/W	R/W	R/W	R/W	R/W	R/W	-	R/W	-
POR	0	0	0	0	0	x	0	x

Bit Number	Bit Mnemonic	Description
7	TF1	Timer1 overflow flag bit Set by hardware on Timer/Counter overflow. Cleared by hardware when the processor vectors to interrupt routine.
6	TR1	Timer1 run control bit Set/cleared by software to turn Timer/Counter on/off.
5	TF0	Timer0 overflow flag bit Set by hardware on Timer/Counter overflow. Cleared by hardware when the processor vectors to interrupt routine.
4	TR0	Timer0 run control bit Set/cleared by software to turn Timer/Counter on/off.
2, 0	-	Reserved

TMOD (89H) Timer Operating Mode Register (Read/Write)

Bit Number	7	6	5	4	3	2	1	0
------------	---	---	---	---	---	---	---	---

Bit Mnemonic	-	C/T1	M11	M01	-	C/T0	M10	M00
R/W	-	R/W	R/W	R/W	-	R/W	R/W	R/W
POR	x	0	0	0	x	0	0	0
	T1				T0			

Bit Number	Bit Mnemonic	Description																				
6	C/T1	Timer or Counter selector 1 0: Cleared for Timer operation (input from internal system clock fsys). 1: Set for Counter operation (input from external pin T1/P1.3).																				
5 ~ 4	M11, M01	Timer1 operating mode <table border="1" data-bbox="592 1144 1449 1778"> <thead> <tr> <th>Mode</th> <th>M11</th> <th>M01</th> <th>Operation</th> </tr> </thead> <tbody> <tr> <td>0</td> <td>0</td> <td>0</td> <td>13-bit TIMER/Counter, TL1 high 3 bits invalid</td> </tr> <tr> <td>1</td> <td>0</td> <td>1</td> <td>16-bit Timer/Counter</td> </tr> <tr> <td>2</td> <td>1</td> <td>0</td> <td>8-bit Auto-Reload Mode. TH1 holds a value which is reloaded into 8-bit Timer/Counter TL1 each time it overflows.</td> </tr> <tr> <td>3</td> <td>1</td> <td>1</td> <td>Timer/Counter 1 is stopped</td> </tr> </tbody> </table>	Mode	M11	M01	Operation	0	0	0	13-bit TIMER/Counter, TL1 high 3 bits invalid	1	0	1	16-bit Timer/Counter	2	1	0	8-bit Auto-Reload Mode. TH1 holds a value which is reloaded into 8-bit Timer/Counter TL1 each time it overflows.	3	1	1	Timer/Counter 1 is stopped
Mode	M11	M01	Operation																			
0	0	0	13-bit TIMER/Counter, TL1 high 3 bits invalid																			
1	0	1	16-bit Timer/Counter																			
2	1	0	8-bit Auto-Reload Mode. TH1 holds a value which is reloaded into 8-bit Timer/Counter TL1 each time it overflows.																			
3	1	1	Timer/Counter 1 is stopped																			
2	C/T0	Timer or Counter selector 0 0: Cleared for Timer operation (input from internal system clock fsys). 1: Set for Counter operation (input from external pin T1/P1.2).																				
1 ~ 0	M10, M00	Timer0 operating mode																				

		Mode	M10	M00	Operation
		0	0	0	13-bit TIMER/Counter, TL0 high 3 bits invalid
		1	0	1	16-bit Timer/Counter
		2	1	0	8-bit Auto-Reload Mode. TH0 holds a value which is reloaded into 8-bit Timer/Counter TL0 each time it overflows.
		3	1	1	Split Timer Mode. TL0 is an 8-bit Timer/Counter controlled by the standard Timer0 control bits. TH0 is only an 8-bit timer controlled by Timer1 control bits
7, 3	-	Reserved			

TMOD[0] ~ TMOD[2] of TMOD register is to set operating mode of T0; TMOD[4] ~ TMOD[6] is to set the operating mode of T1.

The function of timer and counter Tx is selected by the control bit C/Tx of SFR TMOD, and it's operating mode selected by M0x and M1x. Only when TRx, the switch of T0 and T1, is set to 1, will T0 and T1 be enabled

TMCON (8EH) Timer Frequency Control Register (Read/Write)

Bit Number	7	6	5	4	3	2	1	0
Bit Mnemonic	-	-	-	-	-	T2FD	T1FD	T0FD
R/W	-	-	-	-	-	R/W	R/W	R/W
POR	x	x	x	x	x	0	0	0

Bit Number	Bit Mnemonic	Description
1	T1FD	T1 input frequency selection control bit 0: T1 clock source is $f_{sys}/12$ 1: T1 clock source is f_{sys}
0	T0FD	T0 input frequency selection control bit 0: T0 clock source is $f_{sys}/12$ 1: T0 clock source is f_{sys}

IE (A8H) Interrupt Enable Register (Read/Write)

Bit Number	7	6	5	4	3	2	1	0
Bit Mnemonic	EA	EADC	ET2	-	ET1	EINT1	ET0	EINT0
R/W	R/W	R/W	R/W	-	R/W	R/W	R/W	R/W
POR	0	0	0	x	0	0	0	0

Bit Number	Bit Mnemonic	Description
3	ET1	Timer1 interrupt enable control bit 0: Disable Timer1 interrupt 1: Enable Timer1 interrupt
1	ET0	Timer0 interrupt enable control bit 0: Disable Timer0 interrupt 1: Enable Timer0 interrupt

IP (B8H) Interrupt Priority Control Register (Read/Write)

Bit Number	7	6	5	4	3	2	1	0
Bit Mnemonic	-	IPADC	IPT2	-	IPT1	IPINT1	IPT0	IPINT0
R/W	-	R/W	R/W	-	R/W	R/W	R/W	R/W
POR	x	0	0	x	0	0	0	0

Bit Number	Bit Mnemonic	Description
3	IPT1	Timer1 interrupt priority selection bit 0: Configure Timer1 interrupt priority as "low" 1: Configure Timer1 interrupt priority as "high"
1	IPT0	Timer0 interrupt priority selection bit 0: Configure Timer0 interrupt priority as "low" 1: Configure Timer0 interrupt priority as "high"

10.2 T0 Operating Modes

Timer0 can be configured in one of four operating modes by setting the bit pairs (M10, M00) in the TMOD register.

Operating mode 0: 13-bit Timer/Counter

TH0 register is to store the high 8 bits (TH0.7 ~ TH0.0) of 13-bit Timer/Counter and TL0 is to store the low 5 bits (TL0.4 ~ TL0.0). The high three bits of TL0 (TL0.7 ~ TL0.5) are filled with uncertain values, they shall be omitted upon reading. When 13-bit Timer/Counter overflows with count increment, the system will set timer overflow flag TF0 to 1. An interrupt will be generated if the timer0 interrupt is enabled.

C/T0 bit selects the clock input source of Timer/Counter. If C/T0=1, the level fluctuation from high to low of Counter 0 input pin T0 (P1.2) will make Counter 0 data register add 1. If C/T0=0, the frequency division of system clock is the clock source of Timer0.

When TR0 = 1, Timer 0 is enabled. Setting TR0 would not reset the timer forcibly. It means that the timer register will start to count from the value of last clearing of TR0. Therefore, before enable the timer, it is required to configure the initial value of timer register.

When configured as a timer, the SFR T0FD is used to select fractional frequency ratio of clock source.

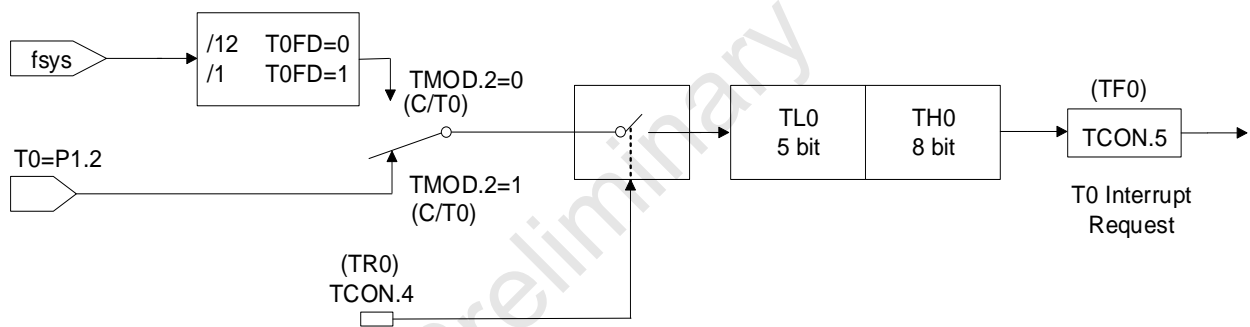

Operating mode 0: 13-bit Timer/Counter

Operating Mode 1: 16 Counter/Timer

Except for using 16 bits of (valid for all 8 bits of TL0) Timer/Counter, in mode 1 and mode 0, the operating mode, opening and configuration method are the same.

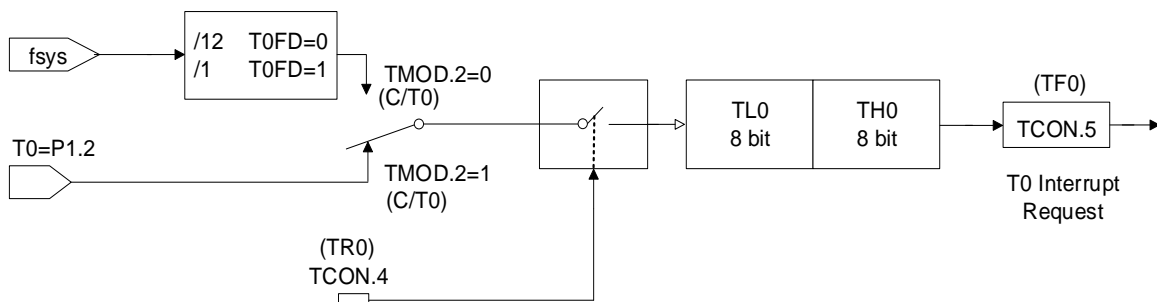

Operating mode 1: 16-bit Timer/Counter

Operating Mode 2: 8 Automatic Reload Counter/Timer

In operating mode 2, Timer0 is 8-bit automatic reload Timer/Counter. TL0 is to store counting value and TH0 is to store the reload value. When the counter in TL0 overflows and turn to 0x00, the overflow flag of Timer TF0 will be set to 1, and the data in register TH0 will be reloaded into register TL0. If the timer interrupt enabled, setting TF0 to 1 will generate an interrupt, but the reloaded value in TH0 will remain the same. Before starting the Timer to count correctly, TL0 shall be initialized to the required value.

Except for automatic reloaded function, the enabling and configuration mode of Timer/Counter in operating mode 2 shall be the same as that in mode 0 and mode 1.

When configured as a timer, the SFR TMCON bit 0 (T0FD) is used to select fractional frequency ratio of system clock f_{sys} .

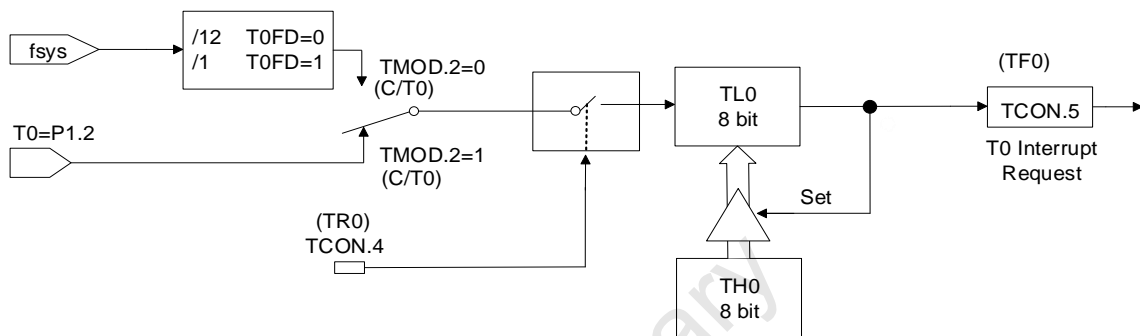

Operating Mode 2: 8 Automatic Reload Counter/Timer

Operating Mode 3: Two 8-bit Counter/Timer (only for Timer0)

In operating mode 3, Timer0 is used as two independent 8-bit Timer/Counters, respectively controlled by TL0 and TH0. TL0 is controlled by control bit (in TCON) and status bit (in TMOD) of Timer0 (TR0), C/T0, TF0. Timer0 is selected as Timer or Counter by TMOD bit 2 (C/T0).

TH0 is only limited to in Timer Mode, which is unable to configure as a Counter by TMOD.2 (C/T0). TH0 is enabled by set the timer control bit TR1 to 1. When overflow occurs and interrupt is discovered, set TF1 to 1 and proceed the interrupt as T1 interrupt.

When T0 is configured in Operating Mode 3, TH0 Timer occupies T1 interrupt resources and TCON register and the 16-bit counter of T1 will stop counting, equivalently "TR1=0". When adopting TH0 timer, it is required to configure TR1=1.

10.3 T1 Operating Modes

Timer1 can be configured in one of three operating modes by setting the bit pairs (M11, M01) in the TMOD register.

Operating mode 0: 13-bit Timer/Counter

TH1 register is to store high 8-bit (TH1.7 ~ TH1.0) of 13-bit Timer/Counter and TL1 is to store low 5-bit (TL1.4 ~ TL1.0). The high 3-bit of TL1 (TL1.7 ~ TL1.5) are uncertain values, they shall be omitted upon reading. When 13-bit Timer/Counter overflow with count increment, the system will set timer overflow flag TF1 as 1. An interrupt will be generated if the timer1 interrupt is enabled. C/T1 bit selects the clock input source of Timer/Counter.

If C/T1=1, the level fluctuation from high to low of timer1 input pin T1 (P1.3) will make timer1 data register add 1. If C/T1=0, the frequency division of system clock is the clock source of timer1.

When TR1 is set to 1 and the timer is enabled. Setting TR1 does not force to reset timer counters, it means, if set TR1 to 1, the timer register will start to count from the value of last clearing of TR1. Therefore, before allowing timer, it is required to configure the initial value of timer register.

When configured as timer, the SFR T1FD is used to select fractional frequency ratio of clock source.

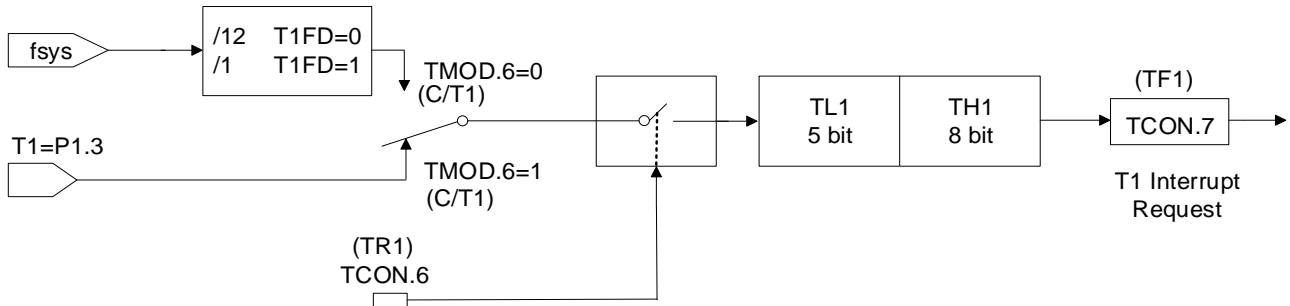

Operating mode 0: 13-bit Timer/Counter

Operating Mode 1: 16 Counter/Timer

Except for using 16-bit (valid for 8-bit data of TL1) Timer/Counter, the operating mode of mode 1 and mode 0 is the same. And the opening and configuration mode of both are also the same.

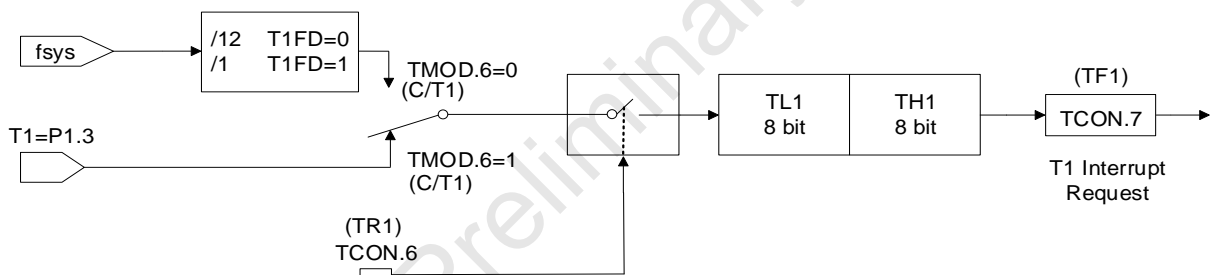

Operating mode 1: 16-bit Timer/Counter

Operating Mode 2: 8 Automatic Reload Counter/Timer

In operating mode 2, Timer1 is 8-bit automatic reload Timer/Counter. TL1 is to store counting value and TH1 is to store the reload value. When the counter in TL1 overflows 0x00, the overflow flag of Timer TF1 will be set to 1, and the value of register TH1 will be reloaded into register TL1. If enable the timer interrupt, setting TF1 to 1 will generate an interrupt, but the reloaded value in TH1 will remain unchanged. Before allowing Timer to correctly count, TL1 shall be initialized to the required value.

Except for automatic reloaded function, the enabling and configuration mode of Timer/Counter in operating mode 2 shall be the same as that of mode 0 and mode 1.

When configured as timer, the SFR TMCON bit 4 (T1FD) is used to select the ratio of clock source of timer to fractional frequency of system clock f_{sys} .

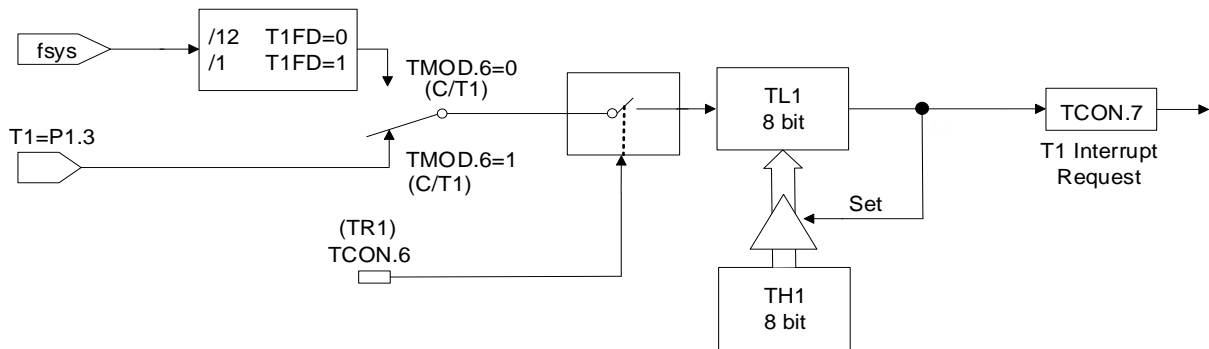

Operating Mode 2: 8 Automatic Reload Counter/Timer

11 Timer/Counter T2

Timer2 inside the SC92F846XB microcontroller unit has two operating modes, namely counter mode and timer mode. There is a control bit C/T2 in SFR T2CON to select Timer or Counter for T2. They are adding counters in nature, differing in counting source. The clock source of T2 comes from system clock or frequency division clock, but the source of counters is the input pulse to external pin. TR2 is the counting switch of Timer/Counter T2. Only when TR2 = 1, will T2 be enabled for counting.

In counter mode, each input pulse on T2 pin will make the counting value of T2 increase by 1.

In timer mode, users can select $f_{sys}/12$ or f_{sys} as counting source of T2 by configuring SFR TMCON.

Timer/Counter T2 has 4 operating modes:

- ① Mode 0: 16-bit capture mode
- ② Mode 1: 16-bit automatic reload timer mode
- ③ Mode 2: Baud rate generator mode
- ④ Mode 3: Programmable clock output mode

11.1 T2-related Registers

Mnemonic	Add	Description	7	6	5	4	3	2	1	0	POR
T2CON	C8H	Timer2 Control Register	TF2	EXF2	RCLK	TCLK	EXEN2	TR2	C/T2	CP/RL2	0000000b
T2MOD	C9H	Timer2 Operating Mode Register	-	-	-	-	-	-	T2OE	DCEN	xxxxxx00b
RCAP2L	CAH	Timer2 Reload/Capture Low Byte	RCAP2L[7: 0]								0000000b

RCAP2H	CBH	Timer2 Reload/Capture High Byte	RCAP2H[7: 0]							0000000b	
TL2	CCH	Timer2 Low Byte	TL2[7: 0]							0000000b	
TH2	CDH	Timer2 High Byte	TH2[7: 0]							0000000b	
TMCON	8EH	Timer Frequency Control Register	-	-	-	-	-	T2FD	T1FD	T0FD	xxxxx000b

Register instructions are shown below:

T2CON (C8H) Timer2 Control Register (Read/Write)

Bit Number	7	6	5	4	3	2	1	0
Bit Mnemonic	TF2	EXF2	RCLK	TCLK	EXEN2	TR2	C/T2	CP/RL2
R/W	R/W	R/W	R/W	R/W	R/W	R/W	R/W	R/W
POR	0	0	0	0	0	0	0	0

Bit Number	Bit Mnemonic	Description
7	TF2	Timer2 overflow flag bit 0: No overflow (must be cleared by software) 1: Overflow (if RCLK=0 and TCLK=0, set to 1 by hardware)
6	EXF2	T2EX pin external event input (falling edge) detected flag bit 0: No external event input (must be cleared by software) 1:When detecting external input (if EXEN2=1, SET to 1 by hardware)
5	RCLK	UART receiving clock control bit 0: Timer1 generates receiving baud rate 1: Timer2 generates receiving baud rate

4	TCLK	<p>UART transmitting clock control bit</p> <p>0: Timer1 generates transmitting baud rate</p> <p>1: Timer2 generates transmitting baud rate</p>
3	EXEN2	<p>External event input (falling edge) on T2EX pin used as reload/capture trigger allowed/prohibited control bit</p> <p>0: Omit event on T2EX pin</p> <p>1: When the timer2 is not used as UART clock, a falling edge is detected on T2EX pin and a capture or reload will be generated.</p>
2	TR2	<p>Timer2 start/stop control bit</p> <p>0: Stop Timer2</p> <p>1: Start Timer2</p>
1	C/T2	<p>Timer2 Timer/Counter mode selection bit 2</p> <p>0: Timer mode, used as I/O interface on T2 pin</p> <p>1: Counter mode</p>
0	CP/RL2	<p>Capture/reload mode selection bit</p> <p>0: 16-bit Timer/Counter with reload function</p> <p>1: 16-bit Timer/Counter with capture function, T2EX as timer2 external capture signal input port</p>

T2MOD (C9H) Timer2 Operating Mode Register (Read/Write)

Bit Number	7	6	5	4	3	2	1	0
Bit Mnemonic	-	-	-	-	-	-	T2OE	DCEN
R/W	-	-	-	-	-	-	R/W	R/W
POR	x	X	x	x	x	x	0	0

Bit Number	Bit Mnemonic	Description
1	T2OE	Timer2 output allow bit 0: Set T2 as clock input or I/O port 1: Set T2 as clock output
0	DCEN	Decreasing counting allow bit 0: Prohibits Timer2 as incremental/decreasing counter, Timer2 only used as incremental counter 1: Allow Timer2 as incremental/decreasing timer
7 ~ 2	-	Reserved

TMCON (8EH) Timer Frequency Control Register (Read/Write)

Bit Number	7	6	5	4	3	2	1	0
Bit Mnemonic	-	-	-	-	-	T2FD	T1FD	T0FD
R/W	-	-	-	-	-	R/W	R/W	R/W
POR	x	x	x	x	x	0	0	0

Bit Number	Bit Mnemonic	Description
2	T2FD	T2 input frequency selection control bit 0: T2 clock source is $f_{SYS}/12$ 1: T2 clock source is f_{SYS}

IE (A8H) Interrupt Enable Register (Read/Write)

Bit Number	7	6	5	4	3	2	1	0
Bit Mnemonic	EA	EADC	ET2	-	ET1	EINT1	ET0	EINT0
R/W	R/W	R/W	R/W	-	R/W	R/W	R/W	R/W
POR	0	0	0	x	0	0	0	0

Bit Number	Bit Mnemonic	Description
5	ET2	Timer2 interrupt enable control bit 0: Disable TIMER2 interrupt 1: Enable TIMER2 interrupt

IP (B8H) Interrupt Priority Control Register (Read/Write)

Bit Number	7	6	5	4	3	2	1	0
Bit Mnemonic	-	IPADC	IPT2	-	IPT1	IPINT1	IPT0	IPINT0
R/W	-	R/W	R/W	-	R/W	R/W	R/W	R/W
POR	x	0	0	x	0	0	0	0

Bit Number	Bit Mnemonic	Description
5	IPT2	Timer2 interrupt priority selection bit 0: Configure Timer2 interrupt priority as "low" 1: Configure Timer2 interrupt priority as "high"

11.2 T2 Operating Modes

The operating mode and configuration mode of Timer2 are shown in the table below:

C/T2	T2OE	DCEN	TR2	CP/RL2	RCLK	TCLK	Mode	
X	0	X	1	1	0	0	0	16-bit capture
X	0	0	1	0	0	0	1	16-bit automatic reload timer
X	0	1	1	0	0	0		
X	0	X	1	X	1	X	2	Baud Rate Generator
					X	1		
0	1	X	1	X	0	0	3	Only used for programmable clock
					1	X	3	Programmable clock output with baud rate generator
					X	1		
X	X	X	0	X	X	X	X	Timer2 stops, but T2EX channel is also available
1	1	X	1	X	X	X		Not recommended

Operating Mode 0: 16-bit capture

In capture mode, there are two options for EXEN2 bit in T2CON.

If EXEN2 = 0, Timer2 is taken as 16-bit timer or counter; if ET2 is set to 1, Timer2 will set up TF2 and generate an interrupt when Timer2 overflows.

If EXEN2=1, conduct the same operations as above on Timer2, the falling edge signal on external input T2EX can make current value in TH2 and TL2 captured into RCAP2H and RCAP2L. Besides, the falling edge signal on T2EX can also cause EXF2 in T2CON to be set to 1. If ET2 is set to 1, bit EXTF2, like TF2, will also trigger an interrupt.

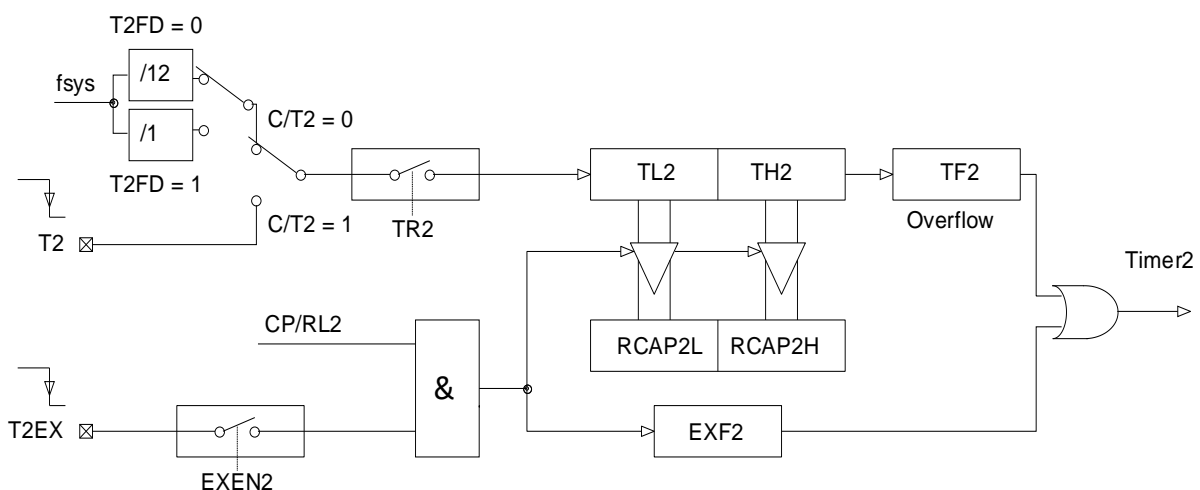

Operating Mode 0: 16-bit capture

Operating Mode 1: 16-bit Automatic Reload Timer

In the 16-bit automatic reload mode, Timer2 can be selected to work in incrementing or decreasing counting mode. This function can be selected by DCEN bit in T2MOD (decreasing counting allowed). After system reset, the reset

value of DCEN bit is 0 and Timer2 is defaulted as decreasing counting. When setting DCEN to 1, the incrementing or decreasing counting depends on the level of T2EX pin.

When DCEN = 0, There are two options for EXEN2 bit in T2CON:

1. EXEN=0, Timer2 will increase to 0xFFFFH and set TF2 bit after overflow. Meanwhile, the timer will load 16-bit value in registers RCAP2H and RCAP2L written by user software into registers TH2 and TL2 automatically.
2. EXEN2=1, both the overflow and the falling edge signal on external input T2EX can trigger a 16-bit count value reloading and set EXF2 bit. If T2 interrupt is enabled (ET2=1), both TF2 and EXF2 bit can generate an interrupt.

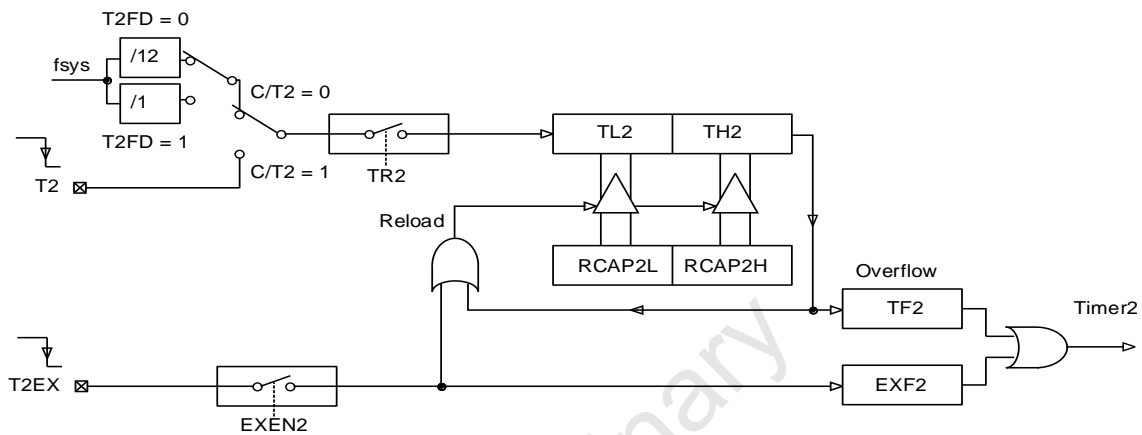

Operating Mode 1: 16-bit Automatic Reload Timer DCEN = 0

Configure CEN bit to allow Timer2 for incremental or decreasing counting. When DCEN=1, T2EX pin controls the count direction, and the control of EXEN2 becomes invalid.

Setting T2EX to 1 can conduct incremental count on Timer2. The Timer overflows when it increases to 0xFFFFH, then it sets TF2 bit. Besides, the overflow can also respectively cause 16-bit value in RCAP2H and RCAP2L to be reloaded into timer registers.

Setting T2EX to 0 can conduct decreasing count on Timer2. When the value in TH2 and TL2 is equal to that of RCAP2H and RCAP2L, the timer overflows. TF2 bit will be set up and 0xFFFFH reloaded into timer register.

No matter whether timer2 overflows or not, bit EXF2 will be used as the 17th bit of the results. Under such operating mode, EXF2 is no longer taken as interrupt flag.

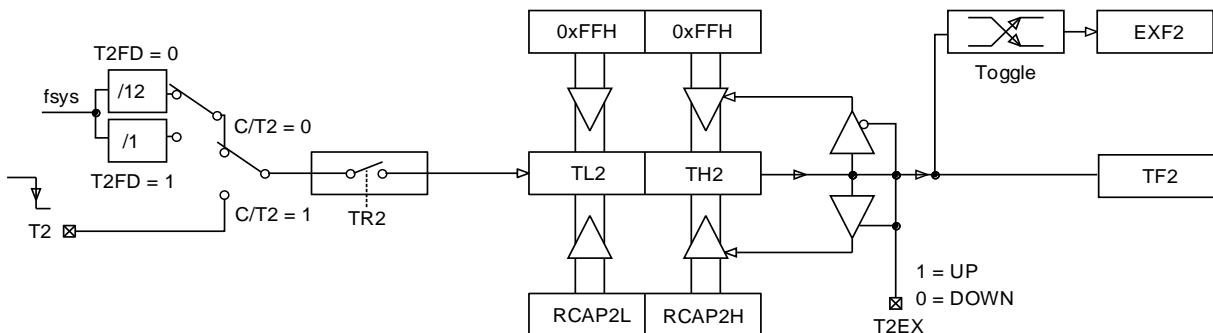

Operating Mode 1: 16-bit Automatic Reload Timer DCEN = 1

Operating Mode 2: Baud Rate Generator

Configure TCLK and RCLK in T2CON register to select Timer2 as baud rate generator. The baud rate of receiver and transmitter can be different. If Timer2 is taken as either one between receiver and transmitter, Timer1 will be taken as another.

Configure TCLK and RCLK in T2CON register to make Timer2 in baud rate generator mode. Such mode is similar to automatic reload mode

Overflow of Timer2 can make the value in registers RCAP2H and RCAP2L reloaded into the Timer2 and counting, but no interrupt will occur.

If EXEN2 is set to 1, the falling edge on T2EX pin will be set up EXF2 without a reloading. Therefore, when Timer2 is taken as baud rate generator, T2EX can be taken as an additional external interrupt

The baud rate of UART mode 1 and mode 3 depends on overflow rate of Timer2 and the following formula:

$$\text{BaudRate} = \frac{f_{\text{sys}}}{[\text{RCAP2H}, \text{RCAP2L}]} ; (\text{note: } [\text{RCAP2H}, \text{RCAP2L}] \text{ must be larger than } 0\text{x}0010)$$

The schematic diagram of Timer2 as baud rate generator is shown as follows:

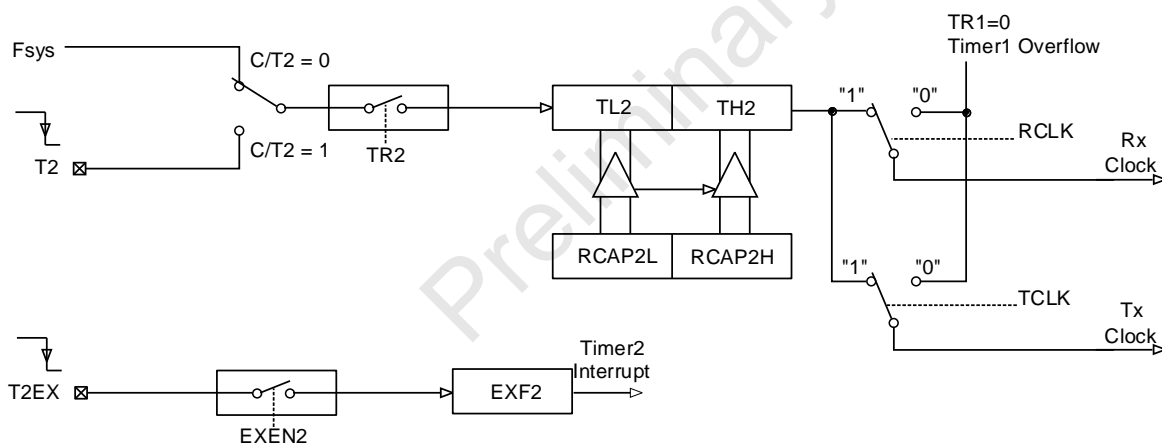

Mode 2: Baud Rate Generator

Operating Mode 3: Programmable Clock Output

In this mode, T2 can be programmed to output a 50% duty cycle clock: when $C/\overline{T2} = 0$ and $T2OE = 1$, Timer2 is taken as clock generator

In this mode, duty cycle of T2 output clock is 50%

$$\text{Colck Out Frequency} = \frac{fn2}{(65536 - [\text{RCAP2H}, \text{RCAP2L}]) \times 4} ;$$

Including, $fn2$ is the clock frequency of Timer2

$$fn2 = \frac{f_{\text{sys}}}{12}; \quad T2FD = 0$$

$$fn2 = f_{\text{sys}}; \quad T2FD = 1$$

Overflow of Timer2 does not generate an interrupt, T2 pin is taken as clock output.

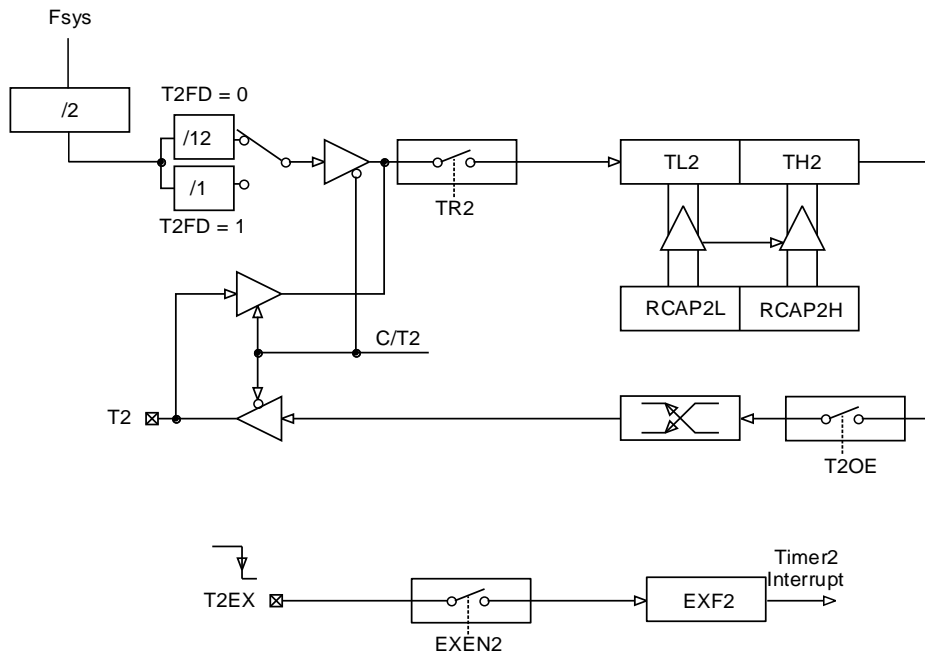

Operating Mode 3: Programmable Clock Output

Note:

1. Both TF2 and EXF2 can generate interrupt request of Timer2, both of which has the same interrupt vector;
2. TF2 and EXF2 can be set by software, only software and hardware reset can clear TF2 and EXF2;
3. When EA = 1 and ET2 = 1, setting up TF2 or EXF2 to 1 can arouse interrupt of Timer2;
4. When Timer2 is taken as baud rate generator, the value written in TH2/TL2 or RCAP2H/RCAP2L may influence the accuracy of baud rate and thus result in error of communication.

12 Multiplier-Divider Unit (MDU)

The SC92F846XB provides a 16-bit multiplier-divider, which is composed of extended accumulator EXA0 ~ EXA3, extended B register EXB and operation control register OPERCON. It can replace the software 16-bit*16-bit multiply operation and 32-bit /16-bit division operation.

Mnemonic	Add	Description	7	6	5	4	3	2	1	0	POR
EXA0	E9H	Extended Accumulator 0	EXA [7: 0]								0000000b
EXA1	EAH	Extended Accumulator 1	EXA [15: 8]								0000000b
EXA2	EBH	Extended Accumulator 2	EXA [23: 16]								0000000b
EXA3	ECH	Extended Accumulator 3	EXA [31: 24]								0000000b
EXBL	EDH	Extended B Register L	EXB [7: 0]								0000000b
EXBH	EEH	Extended B Register H	EXB [15: 8]								0000000b

OPERCON (EFH) Arithmetic Control Register (Read/Write)

Bit Number	7	6	5	4	3	2	1	0
Bit Mnemonic	OPERS	MD	-	-	-	-	-	CHKSUMS
R/W	R/W	R/W	-	-	-	-	-	R/W
POR	0	0	x	x	X	x	x	0

Bit Number	Bit Mnemonic	Description
7	OPERS	Multiplier and divider operation trigger control bit (Operator Start) Set to start a new multiply-divide operation, this bit is only the trigger signal calculated with multiplier, when this bit is zero, the calculation is

		completed. This bit is only valid for writing 1.																																													
6	MD	<p>Multiplier and divider selection bit</p> <p>0: Multiply operation, writing of multiplicand and multiplier and reading of product are shown below:</p> <table border="1"> <thead> <tr> <th>Byte Operations</th> <th>Byte 3</th> <th>Byte 2</th> <th>Byte 1</th> <th>Byte 0</th> </tr> </thead> <tbody> <tr> <td>multiplicand 16bits</td> <td>-</td> <td>-</td> <td>EXA1</td> <td>EXA0</td> </tr> <tr> <td>multiplier 16bits</td> <td>-</td> <td>-</td> <td>EXBH</td> <td>EXBL</td> </tr> <tr> <td>product 32bits</td> <td>EXA3</td> <td>EXA2</td> <td>EXA1</td> <td>EXA0</td> </tr> </tbody> </table> <p>1: Division operation: writing of dividend and divisor and reading of quotient and remainder are shown below:</p> <table border="1"> <thead> <tr> <th>Byte Operations</th> <th>Byte 3</th> <th>Byte 2</th> <th>Byte 1</th> <th>Byte 0</th> </tr> </thead> <tbody> <tr> <td>dividend 32bits</td> <td>EXA3</td> <td>EXA2</td> <td>EXA1</td> <td>EXA0</td> </tr> <tr> <td>divisor 16bits</td> <td>-</td> <td>-</td> <td>EXBH</td> <td>EXBL</td> </tr> <tr> <td>quotient 32bits</td> <td>EXA3</td> <td>EXA2</td> <td>EXA1</td> <td>EXA0</td> </tr> <tr> <td>remainder 16bits</td> <td>-</td> <td>-</td> <td>EXBH</td> <td>EXBL</td> </tr> </tbody> </table>	Byte Operations	Byte 3	Byte 2	Byte 1	Byte 0	multiplicand 16bits	-	-	EXA1	EXA0	multiplier 16bits	-	-	EXBH	EXBL	product 32bits	EXA3	EXA2	EXA1	EXA0	Byte Operations	Byte 3	Byte 2	Byte 1	Byte 0	dividend 32bits	EXA3	EXA2	EXA1	EXA0	divisor 16bits	-	-	EXBH	EXBL	quotient 32bits	EXA3	EXA2	EXA1	EXA0	remainder 16bits	-	-	EXBH	EXBL
Byte Operations	Byte 3	Byte 2	Byte 1	Byte 0																																											
multiplicand 16bits	-	-	EXA1	EXA0																																											
multiplier 16bits	-	-	EXBH	EXBL																																											
product 32bits	EXA3	EXA2	EXA1	EXA0																																											
Byte Operations	Byte 3	Byte 2	Byte 1	Byte 0																																											
dividend 32bits	EXA3	EXA2	EXA1	EXA0																																											
divisor 16bits	-	-	EXBH	EXBL																																											
quotient 32bits	EXA3	EXA2	EXA1	EXA0																																											
remainder 16bits	-	-	EXBH	EXBL																																											

Note:

1. During the operation process, it is forbidden to read or write EXA and EXB data registers.
2. The time for operation conversion of multiplier is $16/f_{\text{SYS}}$.

13 PWM

The SC92F846XB provides an independent counter, which is able to support 6-channel PWM output: PWM0 ~ 5.

The SC92F846XB PWM has the following functions:

- ① 10-bit precision;
- ② Output can be configured in forward or reverse direction;
- ③ Independent mode and complementary mode:
 - 1) In independent mode, PWM0 ~ 5 shared the same clock cycle, but the duty cycle of each PWM channel can be configured separately;
 - 2) In complementary mode, three pairs of complementary PWM waveform with dead zone can be output simultaneously;
- ④ Provide one PWM overflow interrupt.

The cycle and duty cycle of the SC92F846XB PWM is adjustable. Registers PWMCFG, PWMCON controll PWM status and cycle as well as opening of each channel of PWM and duty cycle of output waveform can be adjusted separately.

13.1 PWM block Diagram

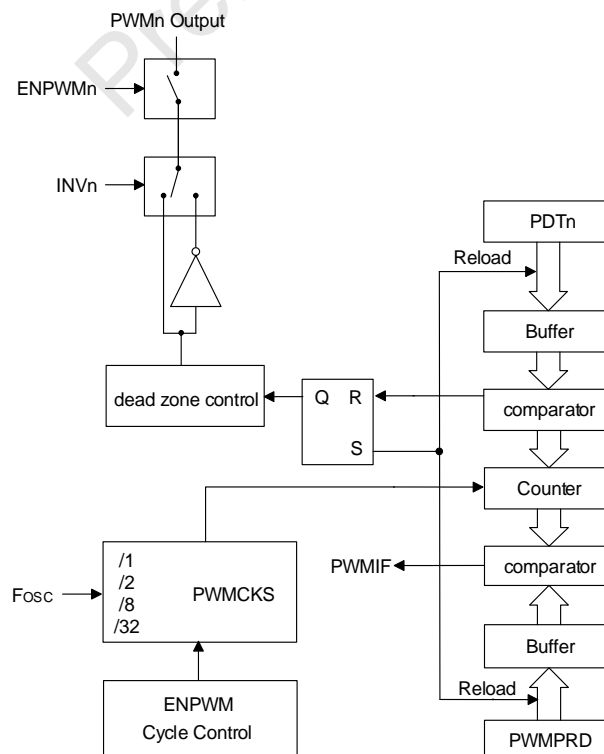

The SC92F846XB PWM block Diagram

13.2 PWM-related Registers

Mnemonic	Add	Description	7	6	5	4	3	2	1	0	POR
PWMCFG	D1H	PWM Configuration Register	PWMCKS[1: 0]		INV5	INV4	INV3	INV2	INV1	INV0	0000000b
PWMCON	D2H	PWM Control Register	ENPWM	PWMIF	ENPWM5	ENPWM4	ENPWM3	ENPWM2	ENPWM1	ENPWM0	0000000b
PWMPRD	D3H	PWM Period Setting Register	PWMPRD[9: 2]								0000000b
PWMDTYA	D4H	PWM Duty Cycle Configuration Register A	PWMPRD[1: 0]		PDT2[1: 0]		PDT1[1: 0]		PDT0[1: 0]		0000000b
PWMDTY0	D5H	PWM0 Duty Cycle Configuration Register	PDT0[9: 2]								0000000b
PWMDTY1	D6H	PWM1 Duty Cycle Configuration Register	PDT1[9: 2]								0000000b
PWMDTY2	D7H	PWM2 Duty Cycle Configuration Register	PDT2[9: 2]								0000000b
PWMDTYB	DCH	PWM Duty Cycle Configuration Register B	PWMMOD	-	PDT5[1: 0]		PDT4[1: 0]		PDT3[1: 0]		0x000000b
PWMDTY3	DDH	PWM3 Duty Cycle Configuration Register /PWM Dead zone Configuration Register	PDT3[9: 2]								0000000b
PWMDTY4	DEH	PWM4 Duty Cycle Configuration Register	PDT4[9: 2]								0000000b
PWMDTY5	DFH	PWM5 Duty Cycle Configuration Register	PDT5[9: 2]								0000000b
IE1	A9H	Interrupt Enable register 1	-	-	-	ETK	EINT2	EBTM	EPWM	ESSI	xxx00000b
IP1	B9H	Interrupt Priority Control Register 1	-	-	-	IPTK	IPINT2	IPBTM	IPPWM	IPSSI	xxx00000b

13.3 PWM General Configuration Registers

The SC92F846XB PWM working mode is divided into independent mode and complementary mode. The registers shared by these two modes are as follows:

The user can select PWM clock source from 4 options by configuring PWMCFG[7: 6]. INV0 ~ 5 is used to select if PWM0 ~ 5 output is in reverse direction. PWMPRD [9: 0] is the six-channel PWM shared period configuration controller. When PWM counter counts to the preset value of PWMPRD[9: 0], this counter will skip to 00_h when next PWM CLK comes. That is to say, PWM0-5 period is (PWMPRD [9: 0] + 1) *PWM clock. Users can set PWM0 ~ 5 shared period by configuring PWMPRD [7: 0] and PWMDTYA [7: 6].

Note: To guarantee the data is written correctly, writing operation to PWM period register must follow the sequence of first low 2 bits followed by high 8 bits.

IE1 (A9H) Interrupt Enable Register (Read/Write)

Bit Number	7	6	5	4	3	2	1	0
Bit Mnemonic	-	-	-	ETK	EINT2	EBTM	EPWM	ESSI
R/W	-	-	-	R/W	R/W	R/W	R/W	R/W
POR	x	x	x	0	0	0	0	0

Bit Number	Bit Mnemonic	Description
1	EPWM	PWM Interrupt Control Bit 0: Clear to disable the PWM interrupt 1: Set to enable the interrupt when PWM counter overflows

IP1 (B9H) Interrupt Priority Register 1 (Read/Write)

Bit Number	7	6	5	4	3	2	1	0
Bit Mnemonic	-	-	-	IPTK	IPINT2	IPBTM	IPPWM	IPSSI
R/W	-	-	-	R/W	R/W	R/W	R/W	R/W
POR	x	x	x	0	0	0	0	0

Bit Number	Bit Mnemonic	Description
1	IPPWM	PWM interrupt priority selection bit 0: Clear to configure PWM interrupt priority as “low” 1: Set to configure PWM interrupt priority as “ high”

PWMCON (D2H) PWM Control Register (Read/Write)

Bit Number	7	6	5	4	3	2	1	0
Bit Mnemonic	ENPWM	PWMIF	ENPWM5	ENPWM4	ENPWM3	ENPWM2	ENPWM1	ENPWM0
R/W	R/W	R/W	R/W	R/W	R/W	R/W	R/W	R/W
POR	0	0	0	0	0	0	0	0

Bit Number	Bit Mnemonic	Description
7	ENPWM	PWM module switch control bit (Enable PWM) 1: Enable Clock to enter PWM unit and PWM starts to work 0: PWM unit stops operating and PWM counter resets to zero. PWMn still connects to output pin. If using other functions multiplexed with PWMn output pin, set ENPWMn to 0
6	PWMIF	PWM interrupt flag When PWM counter overflows (that is to say, the figure exceeds PWMPRD), this bit will be automatically set to 1 by hardware. If at this time IE1[1] (EPWM) is set to 1 as well, PWM interrupt generates. Note: Six PWMs share the same period and the same PWM interrupt vector.
5 ~ 0	ENPWMx	PWMx functional switch control bit

	(x=0 ~ 5)	0: PWMx do not output to IO 1: PWMx output to IO
--	-----------	---

PWMCFG (D1H) PWM Configuration Register (Read/Write)

Bit Number	7	6	5	4	3	2	1	0
Bit Mnemonic	PWMCKS[1: 0]		INV5	INV4	INV3	INV2	INV1	INV0
R/W	R/W	R/W	R/W	R/W	R/W	R/W	R/W	R/W
POR	0	0	0	0	0	0	0	0

Bit Number	Bit Mnemonic	Description
7 ~ 6	PWMCKS[1: 0]	PWM clock source selector 00: fosc 01: fosc/2 10: fosc/8 11: fosc/32 fosc definition: 7.4 High-speed rc oscillator Circuit
5 ~ 0	INVx (x=0 ~ 5)	PWMx output reverse control bit 0: PWMx output not invert 1: PWMx output reverse

PWMPRD (D3H) PWM Period Configuration Register (Read/Write)

Bit Number	7	6	5	4	3	2	1	0
Bit Mnemonic	PWMPRD[9: 2]							

R/W	R/W	R/W	R/W	R/W	R/W	R/W	R/W	R/W
POR	0	0	0	0	0	0	0	0

PWMDTYA (D4H) PWM Duty Cycle Configuration Register A (Read/Write)

Bit Number	7	6	5	4	3	2	1	0
Bit Mnemonic	PWMPRD[1: 0]		PDT2[1: 0]		PDT1[1: 0]		PDT0[1: 0]	
R/W	R/W	R/W	R/W	R/W	R/W	R/W	R/W	R/W
POR	0	0	0	0	0	0	0	0

Bit Number	Bit Mnemonic	Description
7 ~ 6	PWMPRD[9: 0]	PWM0 ~ PWM5 shared period configuration bit This figure represents period of PWM0 ~ PWM5 output waveform subtract 1; that is to say, period of PWM output is (PWMPRD [9: 0] + 1) * PWM clock;

PWMDTYB (DCH) PWM Duty cycle Configuration Register B (Read/Write)

Bit Number	7	6	5	4	3	2	1	0
Bit Mnemonic	PWMMOD	-	PDT5[1: 0]		PDT4[1: 0]		PDT3[1: 0]	
R/W	R/W	-	R/W	R/W	R/W	R/W	R/W	R/W
POR	0	x	0	0	0	0	0	0

Bit Number	Bit Mnemonic	Description
7	PWMMOD	<p>PWM Mode Configuration Bit</p> <p>0: Independent Mode: PWM0 ~ 5 duty configuration</p> <p>1: Complementary Mode: PWM0/3, PWM1/4, PWM2/5. The output pulse width of the same group of PWM is the same, which is separately controlled by PDT0 ~ 2[9: 0] and dead zone is configured by register PDT3.</p> <p>Note: When ENPWM = 1, PWM module is enabled. When ENPWMn = 0, PWM output is closed and used as GPIO. At this time, PWM module can be used as a 10-bit Timer, and PWM will still generate interrupt if EPWM (IE1.1) is set to 1.</p>

13.4 PWM Independent Mode

In independent mode (PWMMOD = 0), PWMDTY0 ~ 5, PWMDTYA and PWMDTYB can be used as duty cycle configuration registers of PWM0 ~ 5. The user shall configure PWM output status and period and corresponding duty cycle registers of PWM channel to output PWM waveform with fixed duty cycle output.

13.4.1 PWM Independent Mode Diagram

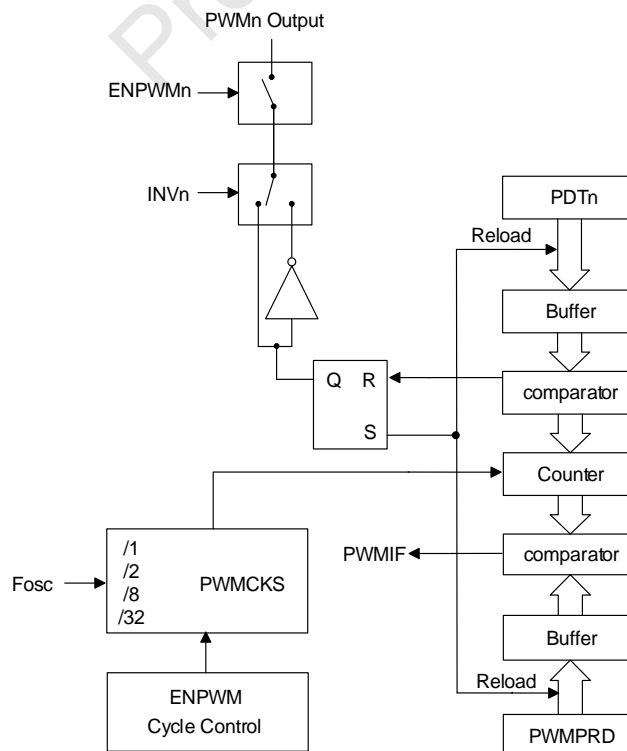

The SC92F846XB PWM Independent Mode Block Diagram

13.4.2 PWM Independent Mode Duty cycle Configuration

To guarantee write data correctly, writing operation to PWM duty cycle registers must follow the sequence of first low 2-bit followed by high-byte.

PWMDTY0 (D5H) PWM0 Duty Cycle Configuration Register (Read/Write)

Bit Number	7	6	5	4	3	2	1	0
Bit Mnemonic	PDT0[9: 2]							
R/W	R/W	R/W	R/W	R/W	R/W	R/W	R/W	R/W
POR	0	0	0	0	0	0	0	0

PWMDTY1 (D6H) PWM1 Duty Cycle Configuration Register (Read/Write)

Bit Number	7	6	5	4	3	2	1	0
Bit Mnemonic	PDT1[9: 2]							
R/W	R/W	R/W	R/W	R/W	R/W	R/W	R/W	R/W
POR	0	0	0	0	0	0	0	0

PWMDTY2 (D7H) PWM2 Duty Cycle Configuration Register (Read/Write)

Bit Number	7	6	5	4	3	2	1	0
Bit Mnemonic	PDT2[9: 2]							
R/W	R/W	R/W	R/W	R/W	R/W	R/W	R/W	R/W
POR	0	0	0	0	0	0	0	0

PWM3 Duty Cycle Configuration Register (Read/Write)

Bit Number	7	6	5	4	3	2	1	0
Bit Mnemonic	PDT3[9: 2]							
R/W	R/W	R/W	R/W	R/W	R/W	R/W	R/W	R/W
POR	0	0	0	0	0	0	0	0

PWM4 Duty Cycle Configuration Register (Read/Write)

Bit Number	7	6	5	4	3	2	1	0
Bit Mnemonic	PDT4[9: 2]							
R/W	R/W	R/W	R/W	R/W	R/W	R/W	R/W	R/W
POR	0	0	0	0	0	0	0	0

PWM5 Duty Cycle Configuration Register (Read/Write)

Bit Number	7	6	5	4	3	2	1	0
Bit Mnemonic	PDT5[9: 2]							
R/W	R/W	R/W	R/W	R/W	R/W	R/W	R/W	R/W
POR	0	0	0	0	0	0	0	0

Bit Number	Bit Mnemonic	Description
7 ~ 0	PDTx[9: 2]	Independent Mode:

	(x=0 ~ 5)	PWMx duty cycle length configuration of high 8 bits; High level width of PWMx is (PDTx[9: 0]) PWM clocks.
--	-----------	--

PWMDTYA (D4H) PWM Duty cycle Configuration Register (Read/Write)

Bit Number	7	6	5	4	3	2	1	0
Bit Mnemonic	PWMPRD[1: 0]		PDT2[1: 0]		PDT1[1: 0]		PDT0[1: 0]	
R/W	R/W	R/W	R/W	R/W	R/W	R/W	R/W	R/W
POR	0	0	0	0	0	0	0	0

PWMDTYB (DCH) PWM Duty Cycle Configuration Register (Read/Write)

Bit Number	7	6	5	4	3	2	1	0
Bit Mnemonic	PWMMOD	-	PDT5[1: 0]		PDT4[1: 0]		PDT3[1: 0]	
R/W	R/W	-	R/W	R/W	R/W	R/W	R/W	R/W
POR	0	x	0	0	0	0	0	0

Bit Number	Bit Mnemonic	Description
5 ~ 0	PDTx [1: 0] (x=0 ~ 5)	PWMx duty cycle length configuration of low 2 bits; High level width of PWMx is (PDTx[9: 0]) PWM clocks.

13.5 PWM Complementary Mode

When the SC92F846XB PWM works in complementary mode, the dead-time control module can prevent the overlap of valid time zones between two complementary output channel PWM signals, so as to guarantee that a pair of complementary power switches tube driven by PWM signals will not work at the same time in practical applications.

In complementary mode (PWMMOD = 1), PWM0 and PWM3 become one group and the duty cycle is to be adjusted by PDT0[9: 0]; PWM1 and PWM4 become one group and the duty cycle is to be adjusted by PDT1[9: 0]; PWM2 and PWM5 become one group and the duty cycle is to be adjusted by PDT2[9: 0].

In complementary mode, the registers PWMDTY4 ~ 5 is invalid, the register PWMDTY3 bit is redefined as PWM3/4/5 falling edge dead zone time control bit PDF[3: 0] and PWM0/1/2 rising edge dead zone time control bit PDR[3: 0].

13.5.1 PWM Complementary Mode Diagram

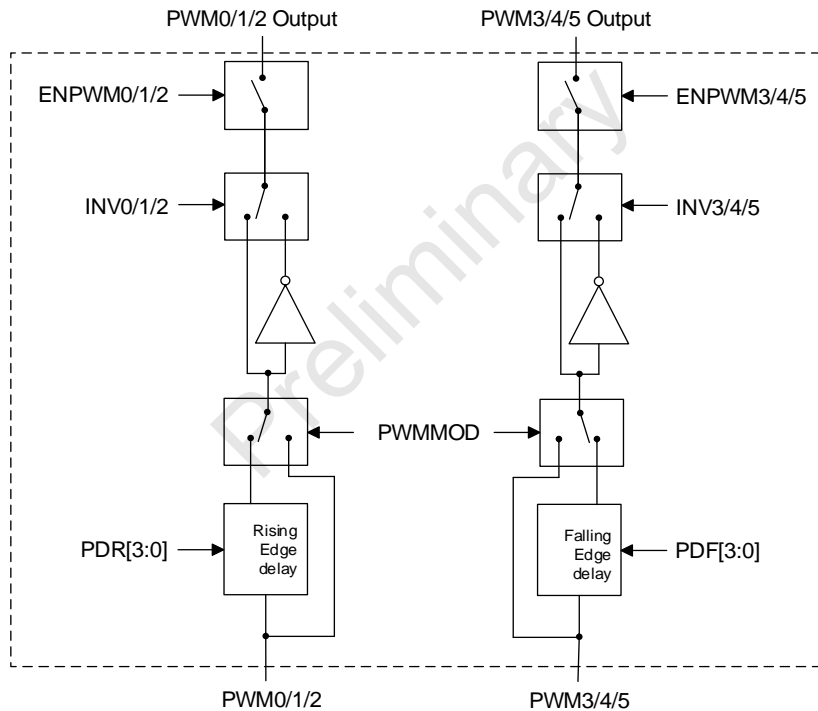

The SC92F846XB PWM Complementary Mode Block Diagram

13.5.2 PWM duty cycle Configuration in complementary mode

Note: To guarantee that data is written correctly, writing operation to PWM duty cycle registers must follow the sequence of first low 2 bits followed by high 8 bits.

PWMDTY0 (D5H) PWM0 Duty Cycle Configuration Register (Read/Write)

Bit Number	7	6	5	4	3	2	1	0
Bit Mnemonic	PDT0[9: 2]							
R/W	R/W	R/W	R/W	R/W	R/W	R/W	R/W	R/W
POR	0	0	0	0	0	0	0	0

PWMDTY1 (D6H) PWM1 Duty Cycle Configuration Register (Read/Write)

Bit Number	7	6	5	4	3	2	1	0
Bit Mnemonic	PDT1[9: 2]							
R/W	R/W	R/W	R/W	R/W	R/W	R/W	R/W	R/W
POR	0	0	0	0	0	0	0	0

PWMDTY2 (D7H) PWM2 Duty Cycle Configuration Register (Read/Write)

Bit Number	7	6	5	4	3	2	1	0
Bit Mnemonic	PDT2[9: 2]							
R/W	R/W	R/W	R/W	R/W	R/W	R/W	R/W	R/W
POR	0	0	0	0	0	0	0	0

PWMDTYA (D4H) PWM Duty Cycle Configuration Register A (Read/Write)

Bit Number	7	6	5	4	3	2	1	0
Bit Mnemonic	PWMPRD[1: 0]		PDT2[1: 0]		PDT1[1: 0]		PDT0[1: 0]	
R/W	R/W	R/W	R/W	R/W	R/W	R/W	R/W	R/W
POR	0	0	0	0	0	0	0	0

Bit Number	Bit Mnemonic	Description
5 ~ 0	PDTx [1: 0] (x=0 ~ 3)	PWMx duty cycle length is configured as low 2 bits; High level width of PWMx is (PDTx[9: 0]) PWM clocks

13.5.3 PWM Dead Zone Time Configuration in Complementary Mode
PWMDTY3 (DDH) PWM Dead zone Configuration Register (Read/Write)

Bit Number	7	6	5	4	3	2	1	0
Bit Mnemonic	PDF[3: 0]				PDR[3: 0]			
R/W	R/W	R/W	R/W	R/W	R/W	R/W	R/W	R/W
POR	0	0	0	0	0	0	0	0

Bit Number	Bit Mnemonic	Description
7 ~ 4	PDF[3: 0]	Complementary model: PWM3/4/5 falling edge dead zone = PDF [3: 0]/fosc

3 ~ 0	PDR[3: 0]	Complementary model: PWM0/1/2 rising edge dead zone = $PDR [3: 0]/f_{osc}$
-------	------------------	---

13.5.4 PWM Dead-time Output Waveform

Below is the waveform diagram for PWM0 and PWM3 adjusted by dead zone under complementary mode, To be better distinguish able, PWM3 is in reverse direction (INV3=1).

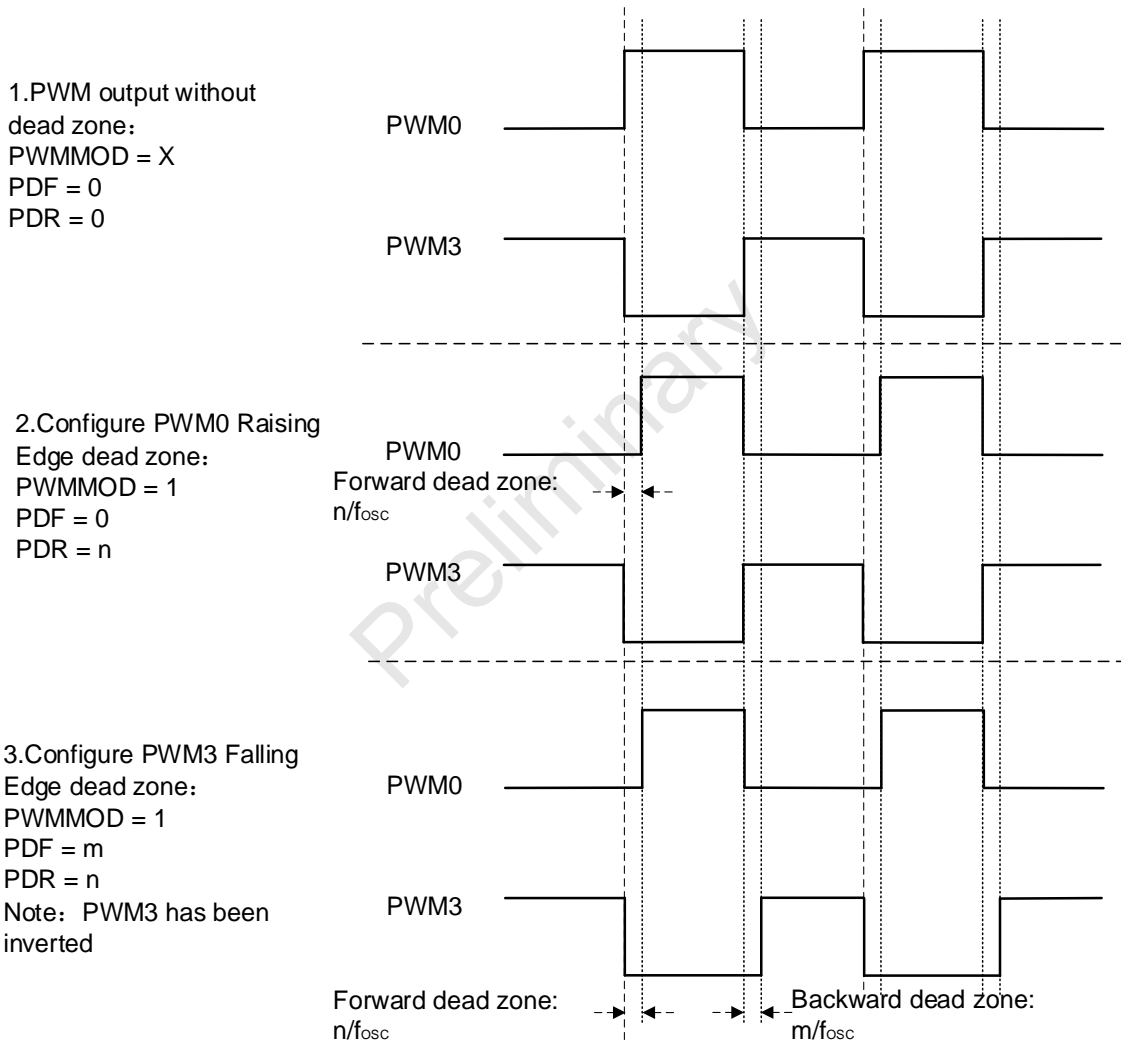

Waveform of PWM Output with Dead Zone

13.6 PWM Waveforms and Directions

The influence of changing various SFR parameters on PWM waveform is shown as follows:

① Diagram for Duty Cycle Change features

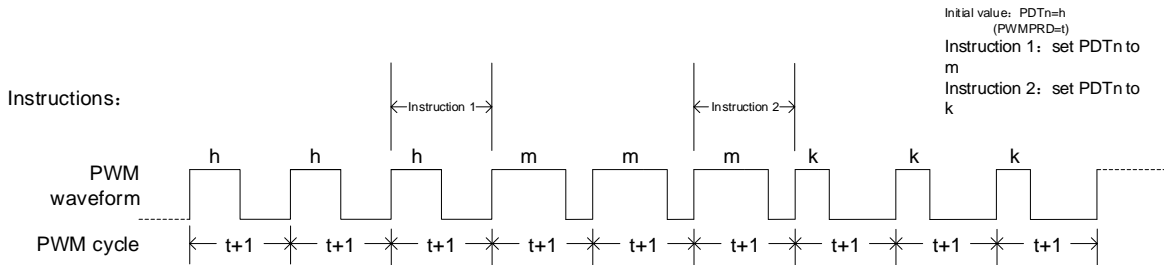

Diagram for Duty Cycle Change Features

When PWMn outputs waveform, if it is required to change the duty cycle, users can change the value of high level configuration registers (PDTn). But note that changing the value of PDTn will not change the duty cycle immediately. It is required to wait until the end of this period and change in the next period. To guarantee write data correctly, writing operations to PWM period and DUTY CYCLE registers must follow the sequence of first low 2 bits followed by high 8 bits. Related waveform output is shown in the figure above.

② Period Change features

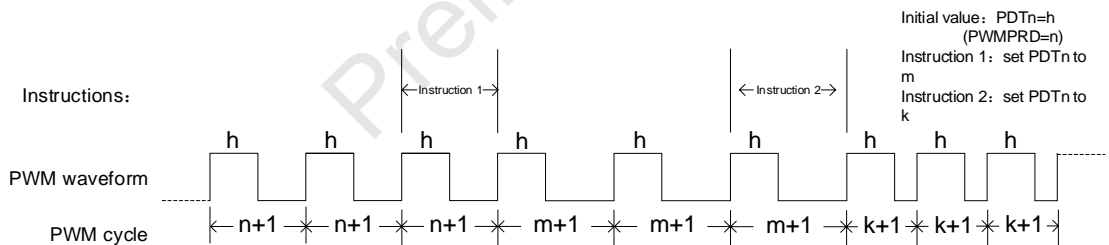

Diagram for Period Change Features

When PWMn outputs waveform, if it is required to change the period, the user can change the value of period configuration registers PWMPRD. Same as changing the duty cycle, change the value of PWMPRD will not change the period immediately. It is required to wait until the end of this period and change in the next period. Refer to the figure above.

③ Relationship between Period and Duty cycle

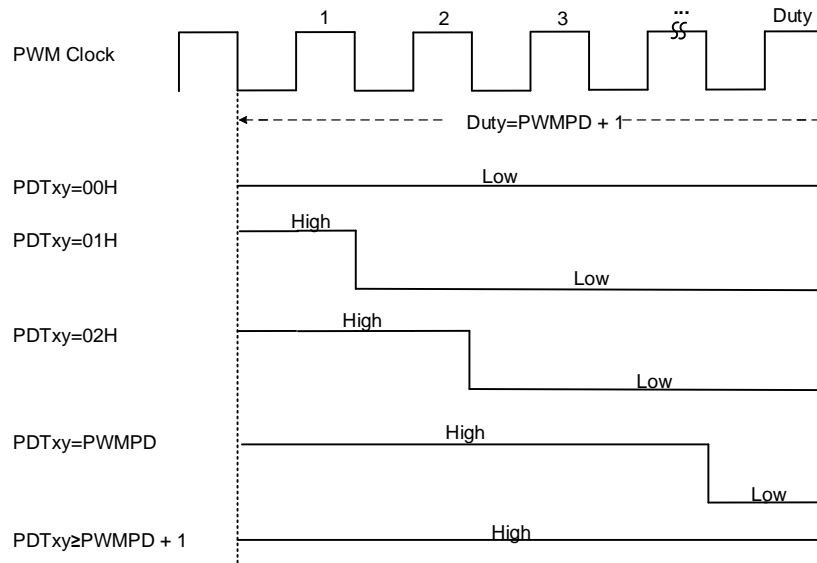

Diagram for Relationship between Period and Duty cycle

The relationship between period and duty cycle is shown in the figure above. The precondition of this result is the PWMn output reverse control (INVn) is initialized to 0; if it is required to get the contrary result, set INVn to 1.

Preliminary

14 General-purpose I/O (GPIO)

The SC92F846XB offers up to 26 bidirectional controllable GPIOs, input and output control registers are used to control the input and output state of various ports, when the port is used as input, each I/O port is equipped with internal pull-up resistor controlled by PxPHY. Such 26 IOs are shared with other functions, including P0.0 ~ P0.4 can be used as LCD COM driver by configuring output voltage as $1/2 V_{DD}$. Under input or output state, what I/O port read from the value of port data register is the actual state value of the port.

Note: Unused IO port or IO port with no package pin shall be configured as strong push-pull output mode.

14.1 GPIO Structure Diagram

Strong Push-pull Output Mode

In strong push-pull output mode, it is able to provide continuous high current drive: high output for the current larger than 20mA and low output for the current larger than 70mA

The port structure diagram for strong push-pull output mode is shown below:

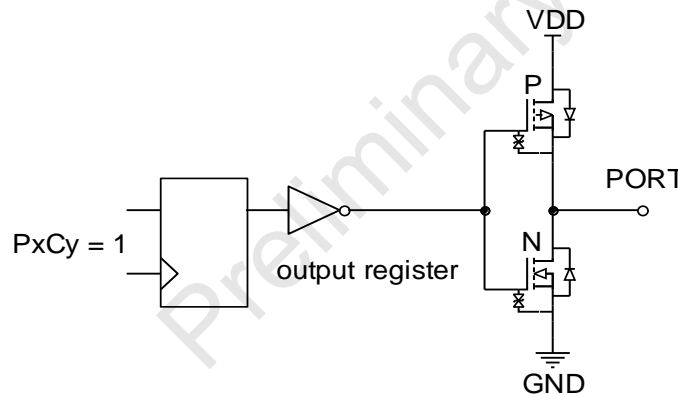

Strong Push-pull Output Mode

Pull-up Input Mode

In pull-up input mode, a pull-up resistor is connected on the input port, only when the level on the input port is pulled down, low level signal can be detected.

The port structure diagram for pull-up input mode is shown below:

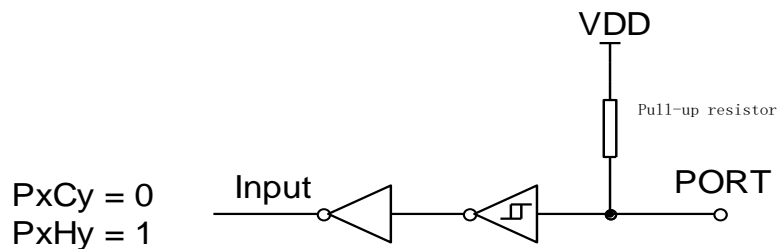

Pull-up Input Mode

High Impedance Input Mode. (Input only)

The port structure diagram for input only mode is shown below:

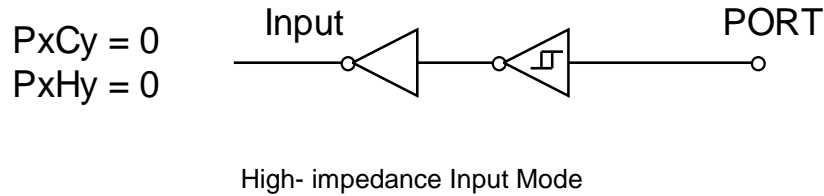

14.2 I/O Port-related Registers

P0CON (9AH) P0 I/O Control Register (Read/Write)

Bit Number	7	6	5	4	3	2	1	0
Bit Mnemonic	P0C7	P0C6	P0C5	P0C4	P0C3	P0C2	P0C1	P0C0
R/W	R/W	R/W	R/W	R/W	R/W	R/W	R/W	R/W
POR	0	0	0	0	0	0	0	0

P0PH (9BH) P0 Pull-up Resistor Control Register (Read/Write)

Bit Number	7	6	5	4	3	2	1	0
Bit Mnemonic	P0H7	P0H6	P0H5	P0H4	P0H3	P0H2	P0H1	P0H0
R/W	R/W	R/W	R/W	R/W	R/W	R/W	R/W	R/W
POR	0	0	0	0	0	0	0	0

P1CON (91H) P1 I/O Control Register (Read/Write)

Bit Number	7	6	5	4	3	2	1	0
Bit Mnemonic	P1C7	P1C6	P1C5	P1C4	P1C3	P1C2	P1C1	P1C0
R/W	R/W	R/W	R/W	R/W	R/W	R/W	R/W	R/W
POR	0	0	0	0	0	0	0	0

P1PH (92H) P1 Pull-up Resistor Control Register (Read/Write)

Bit Number	7	6	5	4	3	2	1	0
Bit Mnemonic	P1H7	P1H6	P1H5	P1H4	P1H3	P1H2	P1H1	P1H0
R/W	R/W	R/W	R/W	R/W	R/W	R/W	R/W	R/W
POR	0	0	0	0	0	0	0	0

P2CON (A1H) P2 I/O Control Register (Read/Write)

Bit Number	7	6	5	4	3	2	1	0
Bit Mnemonic	P2C7	P2C6	P2C5	P2C4	P2C3	P2C2	P2C1	P2C0
R/W	R/W	R/W	R/W	R/W	R/W	R/W	R/W	R/W
POR	0	0	0	0	0	0	0	0

P2PH (A2H) P2 Pull-up Resistor Control Register (Read/Write)

Bit Number	7	6	5	4	3	2	1	0
Bit	P2H7	P2H6	P2H5	P2H4	P2H3	P2H2	P2H1	P2H0

Mnemonic								
R/W	R/W	R/W	R/W	R/W	R/W	R/W	R/W	R/W
POR	0	0	0	0	0	0	0	0

P5CON (D9H) P5 I/O Control Register (Read/Write)

Bit Number	7	6	5	4	3	2	1	0
Bit Mnemonic	-	-	-	-	-	-	P5C1	P5C0
R/W	-	-	-	-	-	-	R/W	R/W
POR	x	x	X	x	x	x	0	0

P5PH (DAH) P5 Pull-up Resistor Control Register (Read/Write)

Bit Number	7	6	5	4	3	2	1	0
Bit Mnemonic	-	-	-	-	-	-	P5H1	P5H0
R/W	-	-	-	-	-	-	R/W	R/W
POR	x	x	X	x	x	x	0	0

Bit Number	Bit Mnemonic	Description
7 ~ 0	PxCy (x=0 ~ 2, 5, y=0 ~ 7)	Px port input and output control bit 0: Pxy as input mode (initial value) 1: Pxy as strong push-pull output mode
7 ~ 0	PxHy	Px port pull-up resistance configuration, only valid when PxCy=0:

	(x=0 ~ 2, 5, y=0 ~ 7)	0: Pxy as high-impedance input mode (initial value), the pull-up resistor is turned off. 1: Pxy pull-up resistance is turned on.
--	-----------------------	---

P0 (80H) P0 Data Register (Read/Write)

Bit Number	7	6	5	4	3	2	1	0
Bit Mnemonic	P0.7	P0.6	P0.5	P0.4	P0.3	P0.2	P0.1	P0.0
R/W	R/W	R/W	R/W	R/W	R/W	R/W	R/W	R/W
POR	0	0	0	0	0	0	0	0

P1 (90H) P1 Data Register (Read/Write)

Bit Number	7	6	5	4	3	2	1	0
Bit Mnemonic	P1.7	P1.6	P1.5	P1.4	P1.3	P1.2	P1.1	P1.0
R/W	R/W	R/W	R/W	R/W	R/W	R/W	R/W	R/W
POR	0	0	0	0	0	0	0	0

P2 (A0H) P2 Data Register (Read/Write)

Bit Number	7	6	5	4	3	2	1	0
Bit Mnemonic	P2.7	P2.6	P2.5	P2.4	P2.3	P2.2	P2.1	P2.0
R/W	R/W	R/W	R/W	R/W	R/W	R/W	R/W	R/W
POR	0	0	0	0	0	0	0	0

P5 (D8H) P5 Data Register (Read/Write)

Bit Number	7	6	5	4	3	2	1	0
Bit Mnemonic	-	-	-	-	-	-	P5.1	P5.0
R/W	-	-	-	-	-	-	R/W	R/W
POR	x	x	x	x	x	x	0	0

IOHCON (97H) IOH Configuration Register (Read/Write)

Bit Number	7	6	5	4	3	2	1	0
Bit Mnemonic	P2H[1: 0]		P2L[1: 0]		POH[1: 0]		POL[1: 0]	
R/W	R/W	R/W	R/W	R/W	R/W	R/W	R/W	R/W
POR	0	0	0	0	0	0	0	0

Bit Number	Bit Mnemonic	Description
7 ~ 6	P2H[1: 0]	P2 high 4-bit IOH configuration bits 00: Set P2 high 4-bit IOH level 0 (Maximum value); 01: Set P2 high 4-bit IOH level 1; 10: Set P2 high 4-bit IOH level 2; 11: Set P2 high 4-bit IOH level 3 (Minimum value);
5 ~ 4	P2L[1: 0]	P2 low 4-bit IOH configuration bits 00: Set P2 low 4-bit IOH level 0 (Maximum value); 01: Set P2 low 4-bit IOH level 1; 10: Set P2 low 4-bit IOH level 2;

		11: Set P2 low 4-bit IOH level 3 (Minimum value);
3 ~ 2	P0H[1: 0]	P0 high 4-bit IOH configuration bits 00: Set P0 high 4-bit IOH level 0 (Maximum value); 01: Set P0 high 4-bit IOH level 1; 10: Set P0 high 4-bit IOH level 2; 11: Set P0 high 4-bit IOH level 3 (Minimum value);
1 ~ 0	P0L[1: 0]	P0 low 4-bit IOH configuration bits 00: Set P0 low 4-bit IOH level 0 (Maximum value); 01: Set P0 low 4-bit IOH level 1; 10: Set P0 low 4-bit IOH level 2; 11: Set P0 low 4-bit IOH level 3 (Minimum value);

15 Software LCD Driver

The P0.0 ~ P0.4 of the SC92F846XB can be used as the COM port of the software LCD. In addition to the normal IO functions, these IOs can also output 1/2VDD. The user can select the corresponding IO as the LCD driver COM according to the usage.

15.1 Software LCD Drives-related Registers

LCD Driver Related SFR Register Description:

P0VO (9CH) P0 port LCD voltage output register (Read/Write)

Bit Number	7	6	5	4	3	2	1	0
Bit Mnemonic	-	-	-	P04VO	P03VO	P02VO	P01VO	P00VO
R/W	-	-	-	R/W	R/W	R/W	R/W	R/W
POR	x	x	x	0	0	0	0	0

P0yVO (y=0 ~ 4)	P0y selection output port
0	Ordinary IO port
1	The output voltage of P0y port is 1/2V _{DD} .

OTCON (8FH) Output Control Register (Read/Write)

Bit Number	7	6	5	4	3	2	1	0
Bit Mnemonic	SSMOD[1: 0]		-	-	VOIRS[1: 0]		-	-
R/W	R/W	R/W	-	-	R/W	R/W	-	-
POR	0	0	x	x	0	0	x	x

Bit Number	Bit Mnemonic	Description
3 ~ 2	VOIRS[1: 0]	Selection bits of voltage dividing resistance of LCD voltage output port (suitable driving according to LCD screen size) 00: Disable internal voltage divider resistor. (Energy saving) 01: Set the internal partial resistance to 12.5K 10: Set the internal partial resistance to 37.5K 11: Set the internal partial resistance to 87.5K

16 Serial Interface 0 (UART0)

The SC92F846XB supports a full-duplex serial port. It is convenient for connecting other device or equipment, for example, WiFi module or other drive chips with UART communication interface. UART0 functions and features are shown below:

1. Three kinds of communication mode: Mode 0, Mode 1 and Mode 3;
2. Configure Timer1 or Timer2 as baud rate generator;
3. Completion of transmission and reception can generate interrupt RI/TI, and such interrupt flag needs to be cleared up by software.

SCON (98H) Serial Port Control Register (Read/Write)

Bit Number	7	6	5	4	3	2	1	0
Bit Mnemonic	SM0	SM1	SM2	REN	TB8	RB8	TI	RI
R/W	R/W	R/W	R/W	R/W	R/W	R/W	R/W	R/W
POR	0	0	0	0	0	0	0	0

Bit Number	Bit Mnemonic	Description
7 ~ 6	SM0 ~ 1	<p>Serial communication mode control bits</p> <p>00: Mode 0, 8-bit half-duplex synchronous communication mode. Serial data is received and transmitted on RX pin. TX pin is used to transmit shift clock. Receive and transmit 8 bits for each frame, and low bits will be received or transmitted firstly;</p> <p>01: Mode 1, 10-bit full-duplex asynchronous communication composing of 1 starting bit, 8 data bits and 1 stopping bit, with communication baud rate changeable;</p> <p>10: Reserved;</p> <p>11: Mode 3, 11-bit full-duplex asynchronous communication, composing of 1 starting bit, 8 data bits and 1 programmable 9th bit and 1 stopping bit, with communication baud rate changeable.</p>
5	SM2	<p>Serial communication mode control bit 2, this control bit is only valid for mode 2 and 3</p> <p>0: RI is set upon receiving a complete data frame to generate interrupt</p>

		request; 1: When receiving a complete data frame, only when RB8=1, will RI be set to generate interrupt request.
4	REN	Receive allowing control bit 0: Receiving data not allowed; 1: Receiving data allowed.
3	TB8	Only valid for mode 2 and 3, 9 th bit of receiving data
2	RB8	Only valid for mode 2 and 3, 9 th bit of receiving data
1	TI	Transmission interrupt flag bit
0	RI	Reception interrupt flag bit

SBUF (99H) Serial Data Cache Register (Read/Write)

Bit Number	7	6	5	4	3	2	1	0
Bit Mnemonic	SBUF[7: 0]							
R/W	R/W	R/W	R/W	R/W	R/W	R/W	R/W	R/W
POR	0	0	0	0	0	0	0	0

Bit Number	Bit Mnemonic	Description
7 ~ 0	SBUF[7: 0]	Serial Port Data Cache Register SBUF contains two registers: one for transmitting shift register and one for receiving latch; data written into SBUF will be transmitted to shift register and initiate transmitting process; reading SBUF will return the contents of receiving latch.

PCON (87H) Power Management Control Register (only readable, * unreadable*)

Bit Number	7	6	5	4	3	2	1	0
Bit Mnemonic	SMOD	-	-	-	-	-	STOP	IDL
R/W	W	-	-	-	-	-	W	W
POR	0	x	x	x	x	x	0	0

Bit Number	Bit Mnemonic	Description
7	SMOD	Baud rate multiplying power configuration bit, only valid for mode 0 (SM0 ~ 1 = 00): 0: Serial port operates under clock of 1/12 system clock 1: Serial port operates under clock of 1/4 system clock

16.1 Baud Rate of Serial Communication

In mode 0, baud rate can be programmed as 1/12 or 1/4 of system clock and determined by SMOD (PCON.7) bit. When SMOD is set to 0, the serial port operates in 1/12 of system clock. When SMOD is set to 1, serial port operates in 1/4 of system clock.

In mode 1 and mode 3, the user can select overflow rate of Timer1 or Timer2 as baud rate by configuration.

Set TCLK (T2CON.4) and RCLK (T2CON.5) bit to configure Timer2 as TX and RX clock source of baud rate (Refer to the timer section for details). No matter TCLK or RCLK is set to logic 1, Timer2 can be in the mode of baud rate generator. If TCLK and RCLK are set to logic 0, Timer1 can be baud clock source of Tx and Rx.

Mode 1 and Mode 3 baud rate formula is shown below, including that [TH1、TL1] are the 16-bit counter registers of Timer1, and [RCAP2H、RCAP2L] are the 16-bit reload registers of Timer2.

1. When Timer1 is used as baud rate generator, it must stop counting, meaning TR1=0:

$$\text{BaudRate} = \frac{f_{\text{sys}}}{[\text{TH1, TL1}]} \quad (\text{Note: } [\text{TH1, TL1}] \text{ must be larger than } 0\text{x}0010)$$

2. When Timer2 is used as baud rate generator:

$$\text{BaudRate} = \frac{f_{\text{sys}}}{[\text{RCAP2H, RCAP2L}]} \quad (\text{Note: } [\text{RCAP2H, RCAP2L}] \text{ must be larger than } 0\text{x}0010)$$

17 SPI/TWI/UART Serial Interface (SSI)

The SC92F846XB integrates SPI/TWI/UART serial interface circuits (SSI), which is convenient for connecting MCU to devices or equipment with different interfaces. The user can configure SSI in any communication mode among SPI, TWI and UART by configuring SSMOD[1: 0] bit of register OTCON. Its features are shown below:

1. SPI mode can be configured as master mode or slave mode
2. TWI mode can only be used as slave in communication
3. UART mode can work in Mode 1 (10-bit full-duplex asynchronous communication) and Mode 3 (11-bit full-duplex asynchronous communication)

Specific configuration modes are shown below:

OTCON (8FH) Output Control Register (Read/Write)

Bit Number	7	6	5	4	3	2	1	0
Bit Mnemonic	SSMOD[1: 0]		-	-	VOIRS[1: 0]		-	-
R/W	R/W	R/W	-	-	R/W	R/W	-	-
POR	0	0	x	x	0	0	x	x

Bit Number	Bit Mnemonic	Description
7 ~ 6	SSMOD[1: 0]	SSI communication mode control bits 00: SSI OFF 01: SSI is set in SPI communication mode; 10: SSI is set in TWI communication mode; 11: SSI is set in UART communication mode;

17.1 Serial Peripheral Interface (SPI)

SSMOD[1: 0] = 01, SSI is configured as SPI interface. Serial Peripheral Interface (SPI) is a kind of high-speed serial communication interface, allowing MCU and peripheral equipment (including other MCUs) to conduct full-duplex synchronous serial communication.

17.1.1 SPI Operation-related Registers

SSCON0 (9DH) SPI Control Register (Read/Write)

Bit Number	7	6	5	4	3	2	1	0
Bit Mnemonic	SPEN	-	MSTR	CPOL	CPHA	SPR2	SPR1	SPR0
R/W	R/W	-	R/W	R/W	R/W	R/W	R/W	R/W
POR	0	x	0	0	0	0	0	0

Bit Number	Bit Mnemonic	Description
7	SPEN	SPI Enable Control Bit 0: Disable SPI 1: Enable SPI
5	MSTR	SPI Master/Slave Selection Bit 0: SPI as slave equipment 1: SPI as master equipment
4	CPOL	Clock Polarity Control Bit 0: SCK is at low level under idle state 1: SCK is at high level under idle state
3	CPHA	Clock Phase Control Bit 0: First edge collection data of SCK period 1: Second edge collection data of SCK period

2 ~ 0	SPR[2: 0]	SPI Clock Speed Selection Bits 000: $f_{SYS} / 4$ 001: $f_{SYS} / 8$ 010: $f_{SYS} / 16$ 011: $f_{SYS} / 32$ 100: $f_{SYS} / 64$ 101: $f_{SYS} / 128$ 110: $f_{SYS} / 256$ 111: $f_{SYS} / 512$
6	-	Reserved

SSCON1 (9EH) SPI Status Register (Read/Write)

Bit Number	7	6	5	4	3	2	1	0
Bit Mnemonic	SPIF	WCOL	-	-	TXE	DORD	-	TBIE
R/W	R/W	R/W	-	-	R/W	R/W	-	R/W
POR	0	0	x	x	0	0	x	0

Bit Number	Bit Mnemonic	Description
7	SPIF	SPI Data Transmit Flag Bit 0: Must be cleared by software 1: Data transmission completed and flag is set to 1 by hardware
6	WCOL	Write-in Conflict Flag Bit 0: Cleared by software, indicating write-in conflict is processed 1: Set to 1 by hardware, indicating one conflict is detected

3	TXE	Transmit Buffer Empty Flag Bit 0: Transmitting buffer not empty 1: Transmitting buffer empty, must be cleared by software
2	DORD	Transfer Direction Configuration Bit 0: Transmit MSB first 1: Transmit LSB first
0	TBIE	Transmitting Buffer Interrupt Enable Bit 0: Transmission interrupt not enable 1: Transmission interrupt enable, when SPIF=1, TBIE=1, it will generate SPI interrupt
5 ~ 4, 1	-	Reserved

SSDAT (9FH) SPI Data Register (Read/Write)

Bit Number	7	6	5	4	3	2	1	0
Bit Mnemonic	SPD[7: 0]							
R/W	R/W	R/W	R/W	R/W	R/W	R/W	R/W	R/W
POR	0	0	0	0	0	0	0	0

Bit Number	Bit Mnemonic	Description
7 ~ 0	SPD[7: 0]	SPI Data Cache Register Data written to SSDAT will be sent to the transmitting shift register. Upon reading SSDAT, data from the receive shift register is received.

17.1.2 Signal Description

Master-Out/Slave-In (MOSI):

This signal connects master device with one slave device. Data is serially transmitted from master device to slave device via MOSI, featuring master device output and slave device input.

Master-In and Slave-Out (MISO):

This signal connects slave device with master device. Data is serially transmitted from slave device to master device via MISO, featuring slave device output and master device input. When SPI is configured as slave device and is not selected, the MISO pin of slave device is in high-impedance state.

SPI Serial Clock (SCK):

SCK signal is used to control synchronous movement of input and output data on MOSI and MISO. Transmit one byte for every 8 clock periods. If no slave device is selected, SCK signal will be ignored from slave device.

17.1.3 Operating Modes

SPI can be configured as master mode or slave mode. The configuration and initialization of SPI module can be completed via setting SCON0 register (SPI Control Register) and SCON1 (SPI State Register). After completing configuration, data is transmitted by setting SCON0, SCON1 and SSDAT (SPI Data Register).

During SPI communication period, data is synchronically and serially moved in or out. Serial clock line (SCK) makes data movement and sampling on two serial data lines (MOSI and MISO) keep synchronous. If any slave device is not selected, it is unable to participate in activities on SPI line.

When SPI master device transmits data to slave device via MOSI, slave device sends data to master device via MISO as response, which realizes synchronous full-duplex transmission of data transmitting and receiving at the same clock. The transmit shift register and the receive shift register use the same special function address. Conducting write operations to SPI data register(SSDAT) will write data to the transmit shift register, and conducting read operations to SSDAT will obtain the data from the receive shift register.

The SPI interface of some devices will lead to SS pin (Slave Select, active-low). When communicating with the SC92F846XB SPI, the SS pin from other devices on SPI bus shall be connected based on different communication modes. The following table lists the connection modes of the SS pin from other devices on SPI bus under different communication modes of the SC92F846XB SPI:

SC92F846XB SPI	Other Devices on SPI Bus	Mode	SS of Slave Device (Slave Device Select Pins)
Master Mode	Slave Mode	One Master One Slave	Pull low
		One Master Multiple Slaves	The SC92F846XB leads to multiple I/Os, which respectively connect to the SS pin of slave device. Before data transmission, the SS pin of slave device must be pulled low
Slave Mode	Master Mode	One Master One Slave	Pull high

Master Mode

- **Mode Startup:**

Start of all data transmission on SPI bus is controlled by SPI master device. When MSTR bit in SSSCON0 register is set to 1, SPI operates in master mode, and only one master device can start the transmission.

- **Transmitting:**

In SPI master mode, write one byte of data to SPI data register SSDAT, the data will write to the transmit shift buffer. If any data already exists in the transmit shift register, one WCOL signal will be generated from master SPI to indicate writing is too fast. However, data in the transmit shift register will not be influenced and transmitting will not be interrupted as well. Besides, if the transmit shift register is empty, the master device will move the data in the transmit shift register to MOSI line serially according to SPI clock frequency on SCK. After transmission, SPIF bit in SSSCON1 register will be set to 1. If SPI interrupt is allowed, when SPIF bit is set to 1, an interrupt will be generated as well.

- **Receiving:**

When master device transmits data to slave device via MOSI line, corresponding slave device will also transmit the contents in the transmit shift register to the receive shift register of master device via MISO line so as to realize full-duplex operations. Therefore, setting SPIF flag bit to 1 indicates that transmission is completed and data has been received. Data received from slave device is stored in the receive shift register of master device in accordance with MSB first or LSB first transmission direction. When one byte of data is completely moved to the receive register, the processor can obtain such data by reading SSDAT register.

Slave Mode

- **Mode Startup:**

When the MSTR bit in SSSCON0 register is clear to 0, SPI operates in slave mode.

- **Transmitting and Receiving:**

In slave mode, according to SCK signal controlled by master device, data is moved in via MOSI pin and out via MISO pin. A 1-bit counter records the number of SCK edge. When the receive shift register moves in 8-bit data (one byte) and the transmit shift register moves out 8-bit data (one byte), SPIF flag is set to 1. Data can be obtained by reading SSDAT register. If SPI interrupt is allowed, when setting SPIF to 1, an interrupt will be generated as well. At this time, the receive shift register keeps original data and set SPIF bit to 1, thus SPI slave device will not receive any data until SPIF is cleared to 0. SPI slave device must write the data to be transmitted before master device starts a new data transmission to the transmit shift register. If no data is written before transmitting, slave device will transmit "0x00" bytes to master device. If SSDAT writing operation occurs during the process of transmission, the WCOL flag bit of SPI slave device is set to 1. That is to say, if data is already included in the transmit shift register, WCOL bit of SPI slave device is set to 1, indicating conflict of SSDAT writing. But the data of shift register will not be influenced and transmission will not be interrupted.

17.1.4 Transfer Form

By setting CPOL bit and CPHA bit of SSSCON0 register by software, the user can select four combinations of SPI clock polarity and clock phase. CPOL bit defines the polarity of clock, meaning the level status when idle, which has little influence on SPI transmission format. CPHA bit defines the phase of clock, meaning clock edge allowing data sampling shift. In two devices of master and slave communication, the configuration of clock polarity and phase shall be consistent.

When CPHA = 0, first edge of SCK captures data, and slave device must get the data ready before the first edge of SCK.

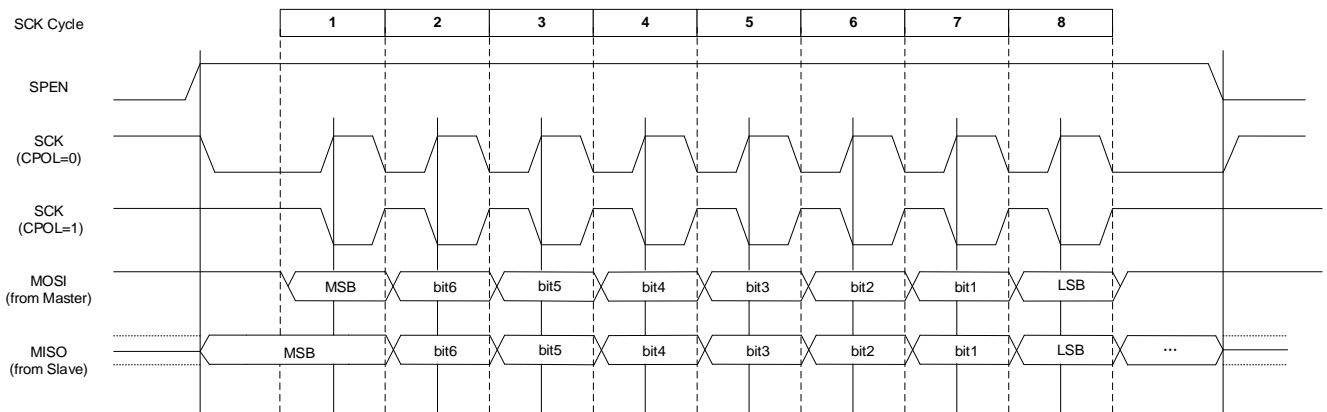

CPHA = 0 Data Transmission

When CPHA = 1, master device outputs data to MOSI line at the first edge of SCK, slave device takes the first edge of SCK as the signal of start transmitting and start capturing data at the second edge of SCK. Therefore, user must complete SSDAT writing operation in two edges of first SCK. Such data transmission form is the preferred form of communication between one master device and one slave device.

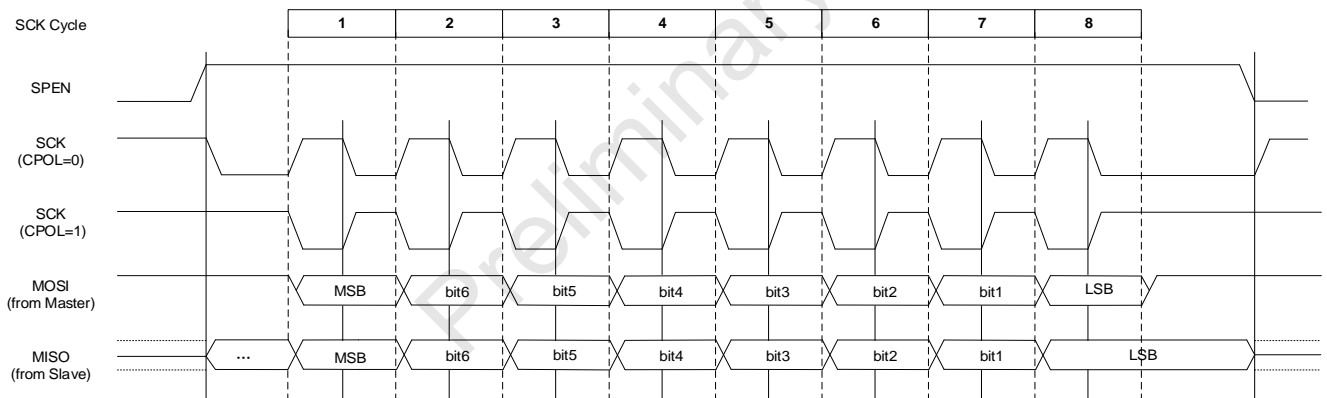

CPHA = 1 Data Transmission

17.1.5 Error Detection

Writing to SSDAT register may cause conflict during the period of transmitting data sequence, set WCOL bit in SSCON1 register to 1. Setting WCOL bit to 1 will not generate interrupt, and transmitting will not be interrupted. WCOL bit shall be cleared by software.

17.2 Two-Wire Interface (TWI)

SSMOD[1: 0] = 10, SSI is configured as TWI interface. The SC92F846XB can only be used as slave device in TWI communication.

SSCON0 (9DH) TWI Control Register (Read/Write)

Bit Number	7	6	5	4	3	2	1	0
Bit Mnemonic	TWEN	TWIF	-	GCA	AA	STATE[2: 0]		
R/W	R/W	R/W	-	R/W	R/W	R/W	R/W	R/W
POR	0	0	x	0	0	0	0	0

Bit Number	Bit Mnemonic	Description
7	TWEN	TWI Enable Control Bit 0: Disable TWI 1: Enable TWI
6	TWIF	TWI Interrupt Flag Bit 0: cleared by software 1: Under the following conditions, interrupt flag bit will be set by hardware ① First frame of address matched successfully ② Successfully receiving or transmitting 8-bit data ③ Restart ④ Slave device receives stopping signal
4	GCA	General Address Response Flag Bit 0: Non-response general address 1: When GC = 1 and the general address matches, this bit will set to 1

		by hardware and cleared to 0 automatically
3	AA	Receiving Enable Bit 0: Information sent by receiving master not allowed 1: Information sent by receiving master allowed
2 ~ 0	STATE[2: 0]	Device status flag Bits 000: slave device is in idle state, wait for TWEN to be set to 1, and detect TWI startup signal. When slave device receives stopping conditions, it will skip to this state 001: Slave device is receiving first frame of address and read and write bits (8 th bit for read and write bit, 1 for reading, 0 for writing). After receiving initial conditions, slave device will skip to this state. 010: State of slave device receiving data 011: State of slave device transmitting data 100: In the state of transmitting data of slave device, when the master device returns to UACK (high level for acknowledge bit), skip to this state, wait for restarting signal or stopping signal. 101: When the slave device is in transmitting state, setting AA to 0 and it will enter this state, waiting for restarting signal or stopping signal.
5	-	Reserved

SSCON1 (9EH) TWI Address Register (Read/Write)

Bit Number	7	6	5	4	3	2	1	0
Bit Mnemonic	TWA[6: 0]							GC
R/W	R/W	R/W	R/W	R/W	R/W	R/W	R/W	R/W
POR	0	0	0	0	0	0	0	0

Bit Number	Bit Mnemonic	Description
7 ~ 1	TWA[6: 0]	TWI Address Register
0	GC	TWI General Address Enable Bit 0: Prohibits responding general address 1: Allow responding general address

SSDAT (9FH) TWI Data Cache Register (Read/Write)

Bit Number	7	6	5	4	3	2	1	0
Bit Mnemonic	TWDAT[7: 0]							
R/W	R/W	R/W	R/W	R/W	R/W	R/W	R/W	R/W
POR	0	0	0	0	0	0	0	0

Bit Number	Bit Mnemonic	Description
7 ~ 0	TWDAT[7: 0]	TWI Data Cache Register

17.2.1 Signal Description

TWI Clock Signal Line (SCL)

This clock signal is sent from master device and connects all slave device. One byte of data is transmitted for every 9 clock periods. First 8 periods are used for data transmission and last one for receiver response clock.

TWI Data Signal Line (SDA)

SDA is a bidirectional signal line, and shall be in high level when idling, which is pulled up by pull-up resistance on SDA line.

17.2.2 Operating Modes

TWI communication of the SC92F846XB has only slave device mode:

- **Mode Startup:**

When TWI enabling flag bit opens (TWEN = 1) and receives start-up signal sent from master device, this mode is initiated.

The slave device enters first frame address (STATE[2: 0] = 001) state from idle mode (STATE[2: 0] = 000), and waits for first frame data from master device. First frame data is sent by master device, including 7-bit address bit and 1-bit read and write bit, all slave devices on TWI bus will receive first frame data of master device. After transmitting first frame data, master device will release SDA signal line. If the address sent by master device is the same as the value of address register of slave device, it indicates that the slave device has been selected and the selected slave device will judge to connect the 8th bit on the bus, which is the data read and write bit (=1, reading the command; =0, writing the command), then occupies SDA signal line, after transmitting a low-level response signal at the 9th clock period of SCL, release the bus. After the slave device is selected, enter into different status according to different read and write bits:

● **Non-general address response, slave device receiving mode:**

If the read and write bit received from the first frame is writing (0), the slave device enters into the receiving state of slave device (STATE [2: 0] = 010), and wait for data sent from receiving master device. Master device will release the bus for transmitting every 8 bits and then wait for the response signal of 9th period of slave device.

1. If the response signal from slave device is in low level, there are three modes of master communication:
 - 1) Continue to send data;
 - 2) Resend start signal, then the slave device enters into the state of receiving first frame address (STATE[2: 0] = 001);
 - 3) Send stopping signal, indicating this transmission is ended, slave device returns to idle state and wait for next start signal from master device.

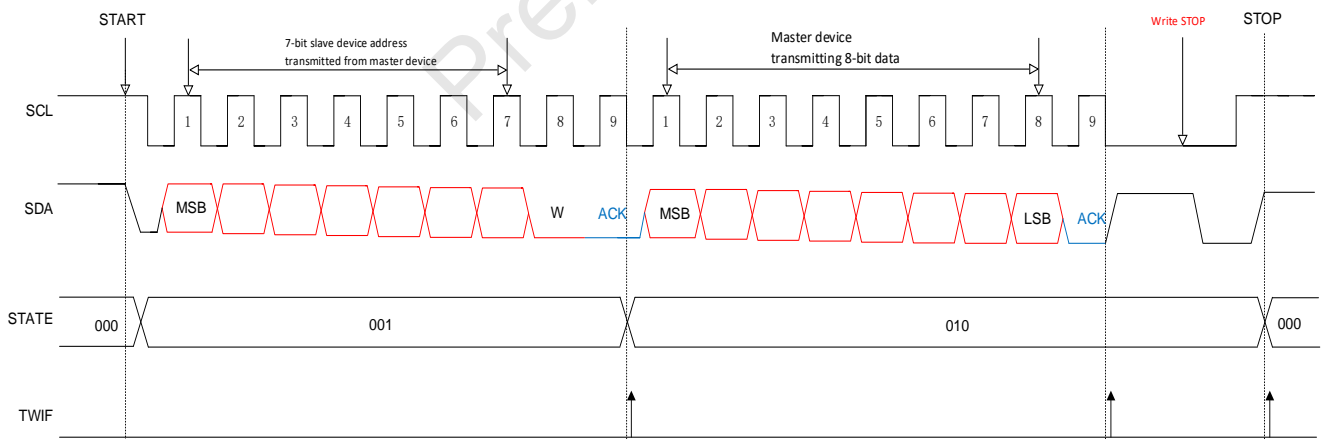

2. If the response state of slave device is in high level (during the receiving process, the value of AA in slave device register is rewritten to 0), it indicates that after transmitting current bytes, the slave device will stop this transmission automatically and return to idle state (STATE[2: 0] = 000), without receiving data sent from master device any more.

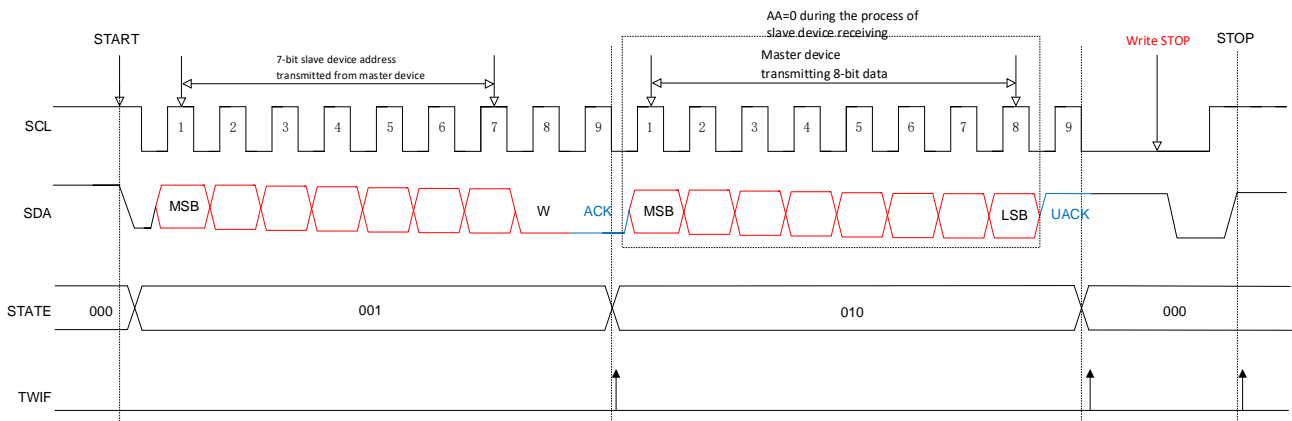

● **Non-general address response, master device transmitting mode:**

If the read and write bit received from the first frame is reading (1), the slave device will occupy the bus and send data to master device. The slave device will release the bus for transmitting every 8-bit data and wait for the response from master device:

1. If the response from master device is low level, the slave device continues to send data. During the transmitting process, if the value of AA in slave device register is rewritten to 0, the slave device will automatically end the transmission and release the bus after transmitting current bytes, and wait for stop signal or restart signal of the master device (STATE[2: 0] = 101).

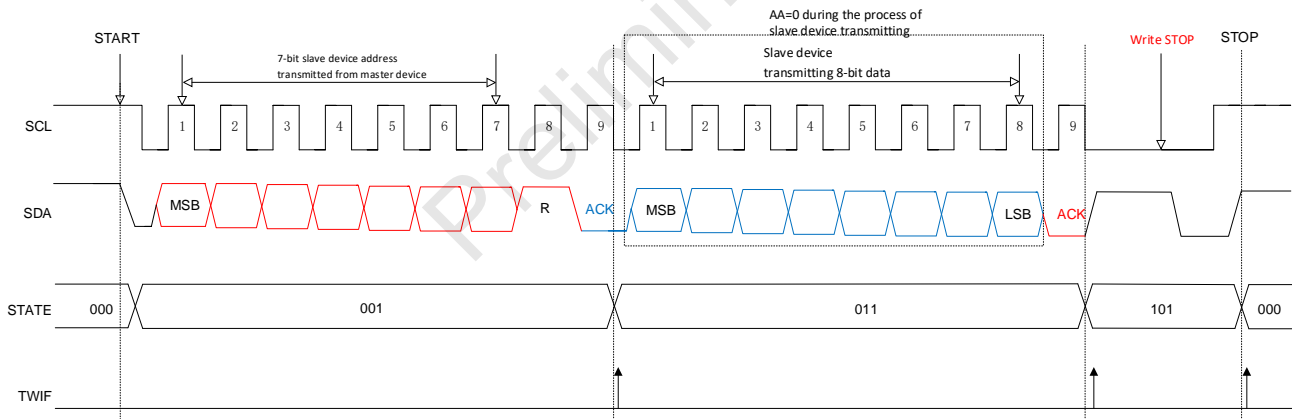

2. If the response from master device is high level, then the slave device state will wait for the stop signal or restart signal of the master device (STATE[2: 0] = 100).

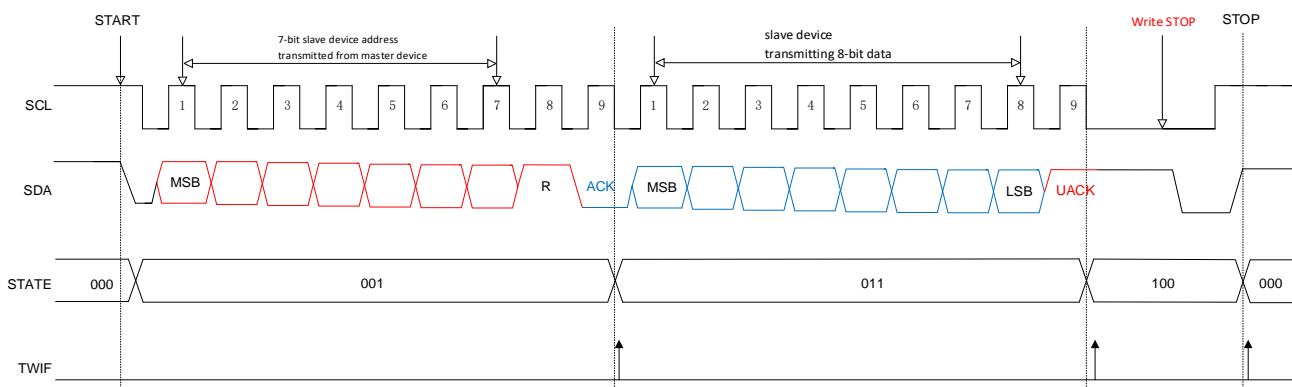

- **Response to General Address:**

When GC=1, general address is allowed to be used. When the slave device enters into the state of receiving first frame address (STATE[2: 0] = 001), the address bit data received in first frame data will be 0x00, at this time, all slave device will respond the master device. The read and write bit sent from master device must be write (0), all slave device will enter into the state of receiving data (STATE[2: 0] = 010). The master device will release SDA line for transmitting every 8-bit data and read the state on SDA line:

1. If any response from slave device occurs, there are three modes of master device communication, as shown below:
 - 1) Continue to transmit data;
 - 2) Restart;
 - 3) Transmit the stop signal and end this communication.

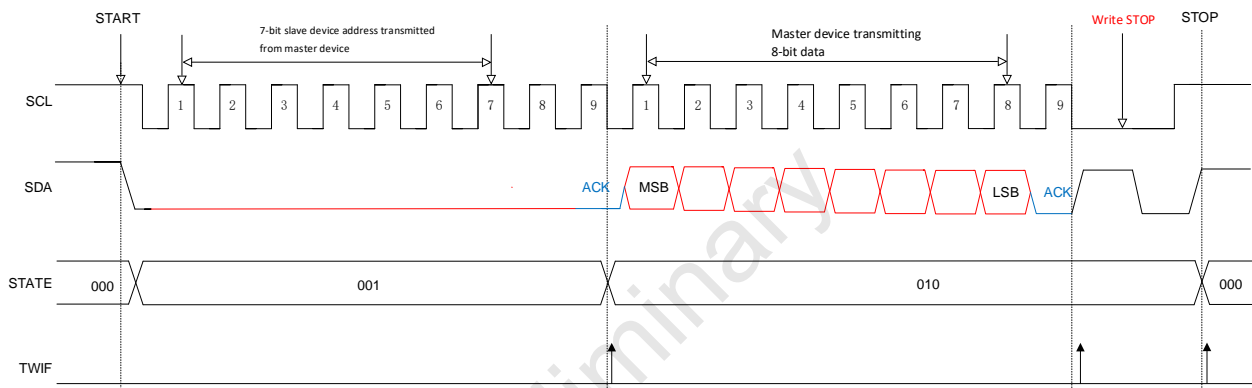

2. If there is no response from slave device, SDA will be in idle state.

Note: When using general address under the mode of one master and multiple slaves, the read and write bit sent by master device can not be read (1) status, or else, all the other devices on the bus will also transmit response except for equipment transmitting data.

17.2.3 Operating Steps

The operating steps of TWI in SSI are shown below:

- ① Configure SSMOD[1: 0] and select TWI mode;
- ② Configure SSSCON0 TWI control register;
- ③ Configure SSSCON1 TWI address register;
- ④ If the slave device receives data, wait for interrupt flag bit TWIF in SSSCON0 to be set. The interrupt flag bit will be set to 1 when the slave device receives every 8-bit data. The interrupt flag bit shall be cleared by the user manually;
- ⑤ If the slave device transmits data, write the data to be transmit into TWDAT, TWI will transmit the data automatically. Interrupt flag bit TWIF will be set to 1 for transmitting every 8 bits.

17.3 Serial Interface 1 (UART1)

SSMOD[1: 0] = 11, SSI is configured as UART interface.

SSCON0 (9DH) Serial Port 1 Control Register (Read/Write)

Bit Number	7	6	5	4	3	2	1	0
Bit Mnemonic	SM0	-	SM2	REN	TB8	RB8	TI	RI
R/W	R/W	-	R/W	R/W	R/W	R/W	R/W	R/W
POR	0	x	0	0	0	0	0	0

Bit Number	Bit Mnemonic	Description
7	SM0	Serial Communication Mode Control Bit 0: Mode 1, 10-bit full-duplex asynchronous communication composing of 1 starting bit, 8 data bits and 1 stopping bit, with communication baud rate changeable; 1: Mode 3, 11-bit full-duplex asynchronous communication, composing of 1 starting bit, 8 data bits and 1 programmable 9 th bit and 1 stopping bit, with communication baud rate changeable.
5	SM2	Serial Communication Mode Control Bit 2, this control bit is only valid for mode 3 0: Configure RI for receiving each complete data frame to generate interrupt request; 1: When receiving a complete data frame and only when RB8=1, will RI be configured to generate interrupt request.
4	REN	Receive Allowing Control Bit 0: Receiving data not allowed; 1: Receiving data allowed.
3	TB8	Only valid for mode 3, 9 th bit of receiving data

2	RB8	Only valid for mode 3, 9 th bit of receiving data
1	TI	Transmit Interrupt Flag Bit
0	RI	Receive Interrupt Flag Bit
6	-	Reserved

SSCON1 (9EH) Serial Port 1 Baud Rate Control Register Low (Read/Write)

Bit Number	7	6	5	4	3	2	1	0
Bit Mnemonic	BAUD1L [7: 0]							
R/W	R/W	R/W	R/W	R/W	R/W	R/W	R/W	R/W
POR	0	0	0	0	0	0	0	0

SSCON2 (95H) Serial Port 1 Baud Rate Control Register Low (Read/Write)

Bit Number	7	6	5	4	3	2	1	0
Bit Mnemonic	BAUD1H [7: 0]							
R/W	R/W	R/W	R/W	R/W	R/W	R/W	R/W	R/W
POR	0	0	0	0	0	0	0	0

Bit Number	Bit Mnemonic	Description
7 ~ 0	BAUD1 [15: 0]	Serial Port Baud Rate Control Bit $\text{BaudRate} = \frac{f_{\text{sys}}}{\text{BAUD1H, BAUD1L}}$

		Note: [BAUD1H, BAUD1L] must be larger than 0x0010
--	--	---

SSDAT (9FH) Serial Port Data Cache Register (Read/Write)

Bit Number	7	6	5	4	3	2	1	0
Bit Mnemonic	SBUF[7: 0]							
R/W	R/W	R/W	R/W	R/W	R/W	R/W	R/W	R/W
POR	0	0	0	0	0	0	0	0

Bit Number	Bit Mnemonic	Description
7 ~ 0	SBUF[7: 0]	Serial Data Buffer SBUF contains two registers: one for transmit shift register and one for receiving latch, data writing to SBUF will be sent to shift register and initiate transmitting process, reading SBUF1 will return the contents of receiving latch.

18 Analog-to-Digital Converter (ADC)

The SC92F846XB has a 12-bit high-precision successive approximation ADC with 11-channel, the external 10 ADC channel is multiplexing with other IO ports. Cooperating with the internal 2.4V reference voltage, one internal channel connected to $1/4 V_{DD}$ can be used for measuring V_{DD} voltage.

There are 2 options for ADC reference voltage:

- ① V_{DD} pin (internal V_{DD});
- ② Precise 2.4V reference output from internal Regulator (at this time, MCU supply voltage V_{DD} can not be lower than 2.9V).

Note: The clock source of ADC circuit is fixed as $f_{HRC} = 24\text{MHz}$, which will not change with the switch of internal and external system clocks.

18.1 ADC-related Registers

ADCCON (ADH) ADC Control Register (Read/Write)

Bit Number	7	6	5	4	3	2	1	0
Bit Mnemonic	ADCEN	ADCS	EOC/ADCIF	ADCIS[4: 0]				
R/W	R/W	R/W	R/W	R/W	R/W	R/W	R/W	R/W
POR	0	0	0	0	0	0	0	n

Bit Number	Bit Mnemonic	Description
7	ADCEN	ADC Power Control Bit 0: Disable ADC module power 1: Enable ADC module power
6	ADCS	ADC Start Trigger Control Bit (ADC Start) Write "1" for this bit, an ADC conversion started, this bit is the trigger signal only for ADC switch. This bit is valid only for writing "1". Note: After writing "1" to ADCS, do not write to the ADCCON register until the interrupt flag EOC/ADCIF is set.

5	EOC /ADCIF	<p>End Of Conversion / ADC Interrupt Flag</p> <p>0: Conversion not completed</p> <p>1: ADC conversion completed and need the user cleared up by software.</p> <p>ADC conversion completion flag EOC: when the user sets up ADCS for conversions, this bit will be cleared to 0 by hardware automatically; after completing conversion, this bit will be configured to 1 automatically by hardware;</p> <p>ADC interrupt request flag ADCIF: this bit is also used as interrupt request flag of ADC interrupt. If ADC interrupt is enabled, this bit must be cleared by the user with software after ADC interrupt generated.</p>
4 ~ 0	ADCIS[4: 0]	<p>ADC Input Selection Bits</p> <p>00000: Select AIN0 as ADC input</p> <p>00001: Select AIN1 as ADC input</p> <p>00010: Select AIN2 as ADC input</p> <p>00011: Select AIN3 as ADC input</p> <p>00100: Select AIN4 as ADC input</p> <p>00101: Select AIN5 as ADC input</p> <p>00110: Select AIN6 as ADC input</p> <p>00111: Select AIN7 as ADC input</p> <p>01000: Select AIN8 as ADC input</p> <p>01001: Select AIN9 as ADC input</p> <p>01010 ~ 11110: Reserved</p> <p>11111: ADC input is 1/4 V_{DD}, used for measuring power voltage</p>

ADCCFG2 (AAH) ADC Configuration Register 2 (Read/Write)

Bit Number	7	6	5	4	3	2	1	0
Bit Mnemonic	-	-	-	-	LOWSP	ADCCCK[2: 0]		
R/W	-	-	-	-	R/W	R/W	R/W	R/W

POR	x	x	x	x	0	0	0	0
-----	---	---	---	---	---	---	---	---

Bit Number	Bit Mnemonic	Description
3	LOWSP	<p>ADC Sampling Clock Frequency Selector</p> <p>0: Configure ADC sampling time as 6 ADC sampling clock periods</p> <p>1: Configure ADC sampling time as 36 ADC sampling clock periods</p> <p>LOWSP controls ADC sampling clock frequency, conversion clock frequency of ADC is controlled by ADCCK[2: 0], independent of the influence of LOWSP bit</p> <p>The whole process from sampling to conversion of ADC needs 6 or 36 ADC sampling clocks plus 14 ADC conversion clocks, therefore, in practical application, the total time of ADC from sampling to conversion shall be calculated as follows:</p> <p>LOWSP=0: $T_{ADC1} = (6+14)/f_{ADC}$;</p> <p>LOWSP=1: $T_{ADC2} = (36+14)/f_{ADC}$</p>
2 ~ 0	ADCCK[2: 0]	<p>ADC Sampling Clock Frequency Selector</p> <p>000: Configure ADC clock frequency f_{ADC} as $f_{HRC}/32$;</p> <p>001: Configure ADC clock frequency f_{ADC} as $f_{HRC}/24$;</p> <p>010: Configure ADC clock frequency f_{ADC} as $f_{HRC}/16$;</p> <p>011: Configure ADC clock frequency f_{ADC} as $f_{HRC}/12$;</p> <p>100: Configure ADC clock frequency f_{ADC} as $f_{HRC}/8$;</p> <p>101: Configure ADC clock frequency f_{ADC} as $f_{HRC}/6$;</p> <p>110: Configure ADC clock frequency f_{ADC} as $f_{HRC}/4$;</p> <p>111: Configure ADC clock frequency f_{ADC} as $f_{HRC}/3$;</p> <p>Note: The clock source of the ADC circuit is fixed as $f_{HRC} = 24\text{MHz}$ and will not change with the switch of the internal and external system clocks.</p>
7 ~ 4	-	Reserved

ADCCFG0 (ABH) ADC Configuration Register 0 (Read/Write)

Bit Number	7	6	5	4	3	2	1	0
Bit Mnemonic	EAIN7	EAIN6	EAIN5	EAIN4	EAIN3	EAIN2	EAIN1	EAIN0
R/W	R/W	R/W	R/W	R/W	R/W	R/W	R/W	R/W
POR	0	0	0	0	0	0	0	0

ADCCFG1 (ACH) ADC Configuration Register 1 (Read/Write)

Bit Number	7	6	5	4	3	2	1	0
Bit Mnemonic	-	-	-	-	-	-	EAIN9	EAIN8
R/W	-	-	-	-	-	-	R/W	R/W
POR	x	x	x	x	x	x	0	0

Bit Number	Bit Mnemonic	Description
0	EAINx (x=0 ~ 9)	ADC Port Configuration Register 0: Configure AINx as IO PORT 1: Configure ANIx as ADC input and remove pull-up resistance automatically.

OP_CTM1 (C2H@FFH) Customer Option Register 1 (Read/Write)

Bit Number	7	6	5	4	3	2	1	0
Bit Mnemonic	VREFS	XTLHF	-	-	IAPS[1: 0]	-	-	-

R/W	R/W	R/W	-	-	R/W	R/W	-	-
POR	n	n	x	x	n	n	x	x

Bit Number	Bit Mnemonic	Description
7	VREFS	Reference Voltage Selection Bit (Default values are configured by the user and loaded from Code Option) 0: Configure ADC VREF as V_{DD} 1: Configure ADC VREF as internal correct 2.4 V

ADCVL (AEH) ADC Conversion Value Register (Low Bit) (Read/Write)

Bit Number	7	6	5	4	3	2	1	0
Bit Mnemonic	ADCV[3: 0]				-	-	-	-
R/W	R/W	R/W	R/W	R/W	-	-	-	-
POR	0	0	0	0	x	x	x	x

ADCVH (AFH) ADC Conversion Value Register (High Bit) (Read/Write)

Bit Number	7	6	5	4	3	2	1	0
Bit Mnemonic	ADCV[11: 4]							
R/W	R/W	R/W	R/W	R/W	R/W	R/W	R/W	R/W
POR	0	0	0	0	0	0	0	0

Bit Number	Bit Mnemonic	Description
11 ~ 4	ADCV[11: 4]	ADC conversion value high byte values
3 ~ 0	ADCV[3: 0]	ADC conversion value low 4-bit values

IE (A8H) Interrupt Enable Register (Read/Write)

Bit Number	7	6	5	4	3	2	1	0
Bit Mnemonic	EA	EADC	ET2	-	ET1	EINT1	ET0	EINT0
R/W	R/W	R/W	R/W	-	R/W	R/W	R/W	R/W
POR	0	0	0	x	0	0	0	0

Bit Number	Bit Mnemonic	Description
6	EADC	ADC Interrupt Enable Control Bit 0: EOC/ADCIF interrupt not allowed 1: EOC/ADCIF interrupt allowed

IP (B8H) Interrupt Priority Control Register (Read/Write)

Bit Number	7	6	5	4	3	2	1	0
Bit Mnemonic	-	IPADC	IPT2	-	IPT1	IPINT1	IPT0	IPINT0
R/W	-	R/W	R/W	-	R/W	R/W	R/W	R/W
POR	x	0	0	x	0	0	0	0

Bit Number	Bit Mnemonic	Description
6	IPADC	ADC Interruption Priority Selection Bit 0: Set the interrupt priority of ADC to be "low" 1: Set the interrupt priority of ADC to be "high"

18.2 ADC Conversion Steps

Operating steps for the user to practically conduct ADC conversion are shown below:

- ① Configure ADC input pin; (configure corresponding bit of AINx as ADC input, in general, ADC pin will be prefixed);
- ② Configure ADC reference voltage Vref and ADC conversion frequency;
- ③ Enable ADC;
- ④ Select ADC input channel; (Configure ADCIS bit and select ADC input channel);
- ⑤ Enable ADCS, and start conversion;
- ⑥ Wait for EOC/ADCIF=1, if ADC interrupt is enabled, ADC interrupt will be generated and the user shall clear EOC/ADCIF flag to 0 by software;
- ⑦ Obtain 12-bit data from ADCVH, ADCVL from high bit to low bit, and complete a conversion
- ⑧ If no change in input channel, repeat Step 5 to Step 7 for next conversion.

Note: Before setting up IE[6] (EADC), it is recommended for the user to use software to clear the EOC/ADCIF flag first. After completing ADC interrupt service process, user shall eliminate EOC/ADCIF to avoid generating ADC interrupt constantly.

19 Dual-mode TouchKey Module

The SC92F846XB is equipped with a built-in dual-mode capsense TouchKey circuit with 23-channel, which is configured as high-sensitivity mode or high-reliability mode, its features are shown below:

1. High-sensitivity mode can be applied to TouchKey application featuring high sensitivity requirements including TouchKey sensor, proximity sensing, etc
2. High-reliability mode features strong anti-interference capability which can pass 10V dynamic CS testing.
3. Realize 23-channel TouchKey sensors and derivative functions
4. High-flexibility development software library is provided for support with low development difficulty
5. Automatic debugging software is provided for support and featuring intelligent development
6. TouchKey module can operate in low-consumption mode under MCU STOP mode, when adopting single TouchKey to wake up STOP, the overall power consumption can be as low as 11uA.

Note: The clock source of the dual-mode TouchKey circuit is fixed as $f_{HRC} = 24\text{MHz}$, and it will not change with the conversion of internal and external system clock.

19.1 Power Saving Modes of TouchKey Module

The SC92F846XB allows TouchKey scan function in STOP Mode, which can reduce the overall power consumption of MCU and satisfy the TouchKey application with low power consumption requirements.

There is two power consumption modes of the SC92F846XB TouchKey circuit:

1. Normal Run Mode
2. Low Consumption Run Mode

The definitions of these two power consumption modes are shown as follows:

Description	Normal Run Mode	Low Power Consumption Run Mode
CPU	RUN (Normal mode)	Stop (STOP Mode)
TouchKey circuit	RUN	RUN

19.2 TouchKey Mode

The SC92F846XB dual-mode TouchKey circuit provides two TouchKey modes:

1. High-sensitivity Mode
2. High-Reliability Model

The user can select TouchKey mode and realize all TouchKey functions quickly and simply by using TouchKey library documents provided by SinOne (available from SinOne website).

The user can select the most appropriate TouchKey mode for current application according the following table:

Description	High-sensitivity Mode	High-Reliability Mode
Features	<ol style="list-style-type: none"> ① High anti-jamming capability, can pass 3V dynamic CS test ② Super- high sensitivity 	<ol style="list-style-type: none"> ① Super anti-jamming capability, can pass 10V dynamic CS test ② Lower power consumption
Applications	<ol style="list-style-type: none"> ① General TouchKey application ② TouchKey sensor application ③ Proximity sensing application ④ TouchKey application featuring high sensitivity requirements 	<ol style="list-style-type: none"> ① Applications featuring super-high anti-interference ② Application with 10V Dynamic CS Requirements
Access Mode	Load high-sensitivity TouchKey library by project engineering to select high-sensitivity mode	Load high-reliability TouchKey library by project engineering to select high-reliability mode
Documentation	<p>《TouchKey MCU Application Guide of SC92F_93F Series》</p> <p>Relevant chapters:</p> <ul style="list-style-type: none"> ● 2 SC92F8XXX_SC93F8XXX_HIGHSENSITIVE_LIB_T1 Library specification ● 3 SC92F8XXX_SC93F8XXX_HIGHSENSITIVE_LIB_T2 Library specification 	<p>《TouchKey MCU Application Guide of SC92F_93F Series》</p> <p>Relevant chapters:</p> <ul style="list-style-type: none"> ● 4 SC92F8XXX_SC93F8XXX_HIGHSENSITIVE_LIB_T1 Library specification
Corresponding Library Document	SC92F8X6XB_HighSensitive_Lib_Tn_Vx.x.x.LIB	SC92F8X6XB_HighReliability_Lib_Tn_Vx.x.x.LIB

Notes	① T1 library applies to spring-type application ② T2 library applies to sensor type application with push buttons more than 3	Only apply to spring-type application
Selection Function	In general, it is recommended to use this high sensitivity mode to obtain better using experience.	Only under two circumstances, it is recommended to use high-reliability mode: ① It is required to use 10V dynamic CS ② It requires lower power consumption current and the current under high sensitivity mode can not meet the requirement.

20 EEPROM and IAP Operations

There are two options for the SC92F846XB IAP operating scope:

EEPROM and IAP operating modes are shown below:

- Internal highest address 128 bytes EEPROM can be used as data storage;
- The whole 16K bytes of IC ROM and 128 bytes of EEPROM can be used for IAP operations, which is mainly used for remote program updating.

Note: The number of erasure of EEPROM is 100,000 times. The user should not exceed the rated burn number of EEPROM, otherwise there will be an exception!

As Code Option, the user shall select IAP operating space before it is written to IC by programmer:

OP_CTM1 (C2H@FFH) Customer Option Register 1 (Read/Write)

Bit number	7	6	5	4	3	2	1	0
Bit Mnemonic	VREFS	XTLHF	-	-	IAPS[1: 0]		-	-
R/W	R/W	R/W	-	-	R/W	R/W	-	-
POR	n	n	x	x	n	n	x	x

Bits	Name	Description
3 ~ 2	IAPS[1: 0]	EEPROM and IAP Area Selection Bits 00: Code memory prohibits IAP operations, only EEPROM data memory is used for data storage 01: last 0.5k code memory allows IAP operation (3E00H ~ 3FFFH) 10: Last 1k code memory allows IAP operation (3C00H ~ 3FFFH) 11: All code memory allows IAP operation (0000H ~ 3FFFH)

20.1 EEPROM / IAP Operating-related Registers

Description for EEPROM / IAP operating-related registers:

Mnemonic	Add	Description	7	6	5	4	3	2	1	0	POR
IAPKEY	F1H	IAP Protection Register	IAPKEY[7: 0]								00000000b
IAPADL	F2H	IAP Write Address Low Register	IAPADR[7: 0]								00000000b
IAPADH	F3H	IAP Write Address High Register	-	-	IAPADR[13: 8]						xx000000b
IAPADE	F4H	IAP Write Extended Address Register	IAPADER[7: 0]								00000000b
IAPDAT	F5H	IAP Data Register	IAPDAT[7: 0]								00000000b
IAPCTL	F6H	IAP Control Register	-	-	-	-	PAYTIMES [1: 0]	CMD[1: 0]		xxxx0000b	

IAPKEY (F1H) IAP Protection Register (Read/Write)

Bit Number	7	6	5	4	3	2	1	0
Bit Mnemonic	IAPKEY[7: 0]							
R/W	R/W	R/W	R/W	R/W	R/W	R/W	R/W	R/W

POR	0	0	0	0	0	0	0	0
-----	---	---	---	---	---	---	---	---

Bit Number	Bit Mnemonic	Description
7 ~ 0	IAPKEY[7: 0]	Enable EEPROM/IAP function and operation time limit configuration, Written values must be non-zero: ① Enable EEPROM / IAP function; ② If no writing command is received after n system clocks, EEPROM / IAP function will be reclosed.

IAPADL (F2H) IAP Write Address Low Register (Read/Write)

Bit Number	7	6	5	4	3	2	1	0
Bit Mnemonic	IAPADR[7: 0]							
R/W	R/W	R/W	R/W	R/W	R/W	R/W	R/W	R/W
POR	0	0	0	0	0	0	0	0

Bit Number	Bit Mnemonic	Description
7 ~ 0	IAPADR[7: 0]	EEPROM/IAP writing address low byte

IAPADH (F3H) IAP Write Address High Register (Read/Write)

Bit Number	7	6	5	4	3	2	1	0
Bit Mnemonic	-	-	IAPADR[13: 8]					
R/W	-	-	R/W	R/W	R/W	R/W	R/W	R/W

POR	x	x	0	0	0	0	0	0
-----	---	---	---	---	---	---	---	---

Bit Number	Bit Mnemonic	Description
5 ~ 0	IAPADR[13: 8]	EEPROM/IAP writing address high 6-bit
7 ~ 6	-	Reserved

IAPADE (F4H) IAP Write Extended Address Register (Read/Write)

Bit Number	7	6	5	4	3	2	1	0
Bit Mnemonic	IAPADER[7: 0]							
R/W	R/W	R/W	R/W	R/W	R/W	R/W	R/W	R/W
POR	0	0	0	0	0	0	0	0

Bit Number	Bit Mnemonic	Description
7 ~ 0	IAPADER[7: 0]	<p>IAP Extended Address:</p> <p>0x00: MOVC and IAP programming for Code</p> <p>0x02: MOVC and IAP programming for EEPROM</p> <p>Note: The number of erasure of EEPROM is 100,000 times. The user should not exceed the rated burn number of EEPROM, otherwise there will be an exception!</p> <p>Other: Reserved</p>

IAPDAT (F5H) IAP Data Register (Read/Write)

Bit Number	7	6	5	4	3	2	1	0
Bit Mnemonic	IAPDAT[7: 0]							
R/W	R/W	R/W	R/W	R/W	R/W	R/W	R/W	R/W
POR	0	0	0	0	0	0	0	0

Bit Number	Bit Mnemonic	Description
7 ~ 0	IAPDAT	Data written by IAP

IAPCTL (F6H) IAP Control Register (Read/Write)

Bit Number	7	6	5	4	3	2	1	0
Bit Mnemonic	-	-	-	-	PAYTIMES[1: 0]		CMD[1: 0]	
R/W	-	-	-	-	R/W	R/W	R/W	R/W
POR	x	x	x	x	0	0	0	0

Bit Number	Bit Mnemonic	Description
3 ~ 2	PAYTIMES[1: 0]	Upon EEPROM/IAP writing operation, CPU Hold Time length configuration 00: Configure CPU HOLD TIME 4mS@12/6/2 MHz 01: Configure CPU HOLD TIME 2mS@12/6/2 MHz 10: Configure CPU HOLD TIME 1mS@12/6/2 MHz 11: Reserved

		<p>Notes: The CPU Hold is for PC pointer, other functional module continues to work; interrupt flag is saved, and interrupt is generated after completing Hold, but several times of interrupt can only be saved once.</p> <p>Recommended Selection: 2.7V ~ 5.5 V for V_{DD}, 10 is available</p> <p>2.4V ~ 5.5V for V_{DD}, 01 or 00 is available</p>
1 ~ 0	CMD[1: 0]	<p>EEPROM / IAP writing operating command</p> <p>10: Write</p> <p>Other: Reserved</p> <p>Note: The statement of EEPROM/IAP write operation shall be followed by at least 8 NOP instructions to guarantee subsequent instruction can be implemented normally after finishing IAP operation!</p>

20.2 EEPROM / IAP Operating Procedures:

Writing procedure of the SC92F846XB EEPROM/IAP are shown below:

- ① Write 0x00 into IAPADE[7: 0]: select Code memory and conduct IAP operation; write 0x02 into IAPADE[7: 0]: select EEPROM and conduct EEPROM reading and writing operations;
- ② Write data into IAPDAT[7: 0] (data for EEPROM / IAP writing ready);
- ③ Write address into {IAPADR[13: 8], IAPADR[7: 0]} (target address of EEPROM/IAP operation ready);
- ④ Write a nonzero value n into IAPKEY[7: 0] (switch on protection of EEPROM / IAP, and EEPROM / IAP function will be switched off when there is no writing command within n system clocks);
- ⑤ Write CPU Hold time into IAPCTL[3: 0] (configure CPU Hold time by setting CMD[1: 0] to 1 or 0, CPU is Hold up and start up EEPROM/IAP writing);
- ⑥ EEPROM/IAP writing ends, CPU proceeds to subsequent operations.

Notes:

1. When programming IC, if “Code memory Prohibits IAP Operations” is selected by Code Option, IAP is unavailable upon IAPADE[7: 0]=0x00 (Select Code memory), meaning it is unable to write data, and such data can only be read by MOVC command.
2. When IAPADE=0x01 or 0x02, MOVC instruction and writing operation are conducted in EEPROM or IFB data memory. If any interrupt occurs and there are also MOVC operations in this interrupt, it may result in error of MOVC operations and thus abnormal operation of program. To avoid such situation, the user shall disable global interrupt control bit (EA=0) before conducting IAPADE=0x01 or 0x02 operations. After operation completed, configure IAPADE =0x00 and enable global interrupt control bit (EA=1).

20.2.1 128 bytes Independent EEPROM Operating Demo program

```
#include "intrins.h"

unsigned char EE_Add;

unsigned char EE_Data;

unsigned char code * POINT =0x0000;
```

C Demo Program of EEPROM Write Operation:

```
EA = 0;                // Disable global Interrupt

IAPADE = 0x02;         //Select EEPROM data memory

IAPDAT = EE_Data;     //Transmit data to EEPROM data register

IAPADH = 0x00;        //High-bit address default write 0x00

IAPADL = EE_Add;      //Write EEPROM target address low bit

IAPKEY = 0xF0;        //This value can be adjusted as required: it shall guarantee that

                        // The time interval between this instruction implemented and writing
                        // IAPCTL value shall be less than 240 (0xf0) system clocks, or else, IAP function
                        // is closed;

                        //Pay special attention to enabling interrupt;

IAPCTL = 0x0A;        //Implement EEPROM write operation, 1ms@12/6/2 MHz;

_nop_ ();             //Wait (at least 8 _nop_ ())

_nop_ ();

_nop_ ();

_nop_ ();

_nop_ ();

_nop_ ();

_nop_ ();

_nop_ ();

_nop_ ();

_nop_ ();

IAPADE = 0x00;        //Return to ROM data memory

EA = 1;               //Enable master interrupt
```

C Demo Program of EEPROM Read Operation

```
EA = 0;                //Disable master interrupt

IAPADE = 0x02;        //Select EEPROM data memory

EE_Data = * ( POINT +EE_Add);    //Read value in IAP_Add to IAP_Data

IAPADE = 0x00;        //Return to ROM data memory, prevent MOVC operates to EEPROM

EA = 1;                // Enable global interrupt
```

20.2.2 16K bytes Code memory IAP Operating Demo program

```
#include "intrins.h"

unsigned int IAP_Add;

unsigned char IAP_Data;

unsigned char code * POINT =0x0000;
```

C Demo Program of IAP Write Operation:

```
IAPADE = 0x00;        //Select Code memory

IAPDAT = IAP_Data;    //Transmit data to IAP data register

IAPADH = (unsigned char) ( (IAP_Add >> 8));    //Write IAP target address high bit

IAPADL = (unsigned char)IAP_Add;        //Write IAP target address low bit

IAPKEY = 0xF0;        //This value can be adjusted as required; it shall guarantee this
//instruction is implemented to assigned IAPCTL value;

// Time interval shall be less than 240 (0xf0) system clocks, or
// else, IAP function is closed;

//Pay special attention upon starting interrupt

IAPCTL = 0x0A;        //Implement EEPROM write operation, 1ms@12/6/2MHz;

_nop_ ();            //Wait (at least 8 _nop_ ())

_nop_ ();

_nop_ ();

_nop_ ();

_nop_ ();

_nop_ ();

_nop_ ();
```

```
_nop_ ();
```

C Demo Program of IAP Read Operation:

```
IAPADE = 0x00;           //Select Code memory

IAP_Data = * ( POINT+IAP_Add); //Read value in IAP_Add to IAP_Data
```

Note: IAP operation in 16K bytes Code memory has certain risks, the user shall implement corresponding safety measures in software. Incorrect operation may result in the user program to be rewritten! Unless such function is required by the user (such as used for remote program update, etc.), it is not recommended to be used by the user.

21 CheckSum Module

The SC92F846XB is equipped with a check sum module, which is used for generating 16-bit check sum of code memory in real time. The user can compare such check sum with theoretical value to monitor whether the contents in code memory are correct.

Note: Check sum is the sum of data in the whole code memory, which is the data of 0000H ~ 3FFDH address unit. If there are residual values from the user's last operations in address unit, it may result in inconsistency of check sum with theoretical value. Therefore, it is recommended that the user shall erase the whole Code memory or write 0 before programming code so as to guarantee the consistency between check sum and theoretical value.

21.1 CheckSum-Related Registers

CHKSUML (FCH) Check Sum Result Register Low Bit (Read/Write)

Bit Number	7	6	5	4	3	2	1	0
Bit Mnemonic	CHKSUML[7: 0]							
R/W	R/W	R/W	R/W	R/W	R/W	R/W	R/W	R/W
POR	0	0	0	0	0	0	0	0

Bit Number	Bit Mnemonic	Description
7 ~ 0	CHKSUML [7: 0]	CheckSum Result Register Low Bit

CHKSUMH (FDH) Check Sum Result Register High Bit (Read/Write)

Bit Number	7	6	5	4	3	2	1	0
Bit Mnemonic	CHKSUMH[7: 0]							
R/W	R/W	R/W	R/W	R/W	R/W	R/W	R/W	R/W
POR	0	0	0	0	0	0	0	0

Bit Number	Bit Mnemonic	Description
7 ~ 0	CHKSUMH [7: 0]	CheckSum Result Register High Bit

OPERCON (EFH) Arithmetic Control Register (Read/Write)

Bit Number	7	6	5	4	3	2	1	0
Bit Mnemonic	-	-	-	-	-	-	-	CHKSUMS
R/W	-	-	-	-	-	-	-	R/W
POR	x	x	x	x	x	x	x	0

Bit Number	Bit Mnemonic	Description
0	CHKSUMS	CheckSum Operation Starts Trigger Control Bit (Start) Write "1" for this bit, start to conduct Check sum calculation. This bit is valid for only writing 1.

22 Electrical Characteristics

22.1 Absolute Maximum Ratings

Symbol	Parameter	Min Value	Max Value	Unit
VDD/VSS	DC supply voltage	-0.3	5.5	V
Voltage ON any Pin	Input/output voltage of any pin	-0.3	V _{DD} +0.3	V
T _A	Ambient temperature	-40	85	°C
T _{STG}	Storage temperature	-55	125	°C

22.2 Recommended Operating Conditions

Symbol	Parameter	Min Value	Max Value	Unit	System Clock Frequency
V _{DD1}	Operating voltage	2.9	5.5	V	>12MHz
V _{DD2}	Operating voltage	2.4	5.5	V	≤12MHz
T _A	Ambient temperature	-40	85	°C	-

23.3 DC Characteristics

(V_{DD} = 5V, T_A = +25°C, unless otherwise specified)

Symbol	Parameter	Min Value	Typical Value	Max Value	Unit	Testing Conditions
Current						

I _{op1}	Operating current	-	8.3	-	mA	f _{sys} =12MHz
I _{op2}	Operating current	-	6.7	-	mA	f _{sys} =6MHz
I _{op3}	Operating current	-	5.7	-	mA	f _{sys} =2MHz
I _{pd1}	Standby Current (Power Down Mode)	-	0.7	1.0	μA	
I _{IDL1}	Standby Current (IDLE Mode)	-	6.0	-	mA	
I _{BTM}	Base Timer Operating Current	-	5.4	7.0	μA	BTMFS[3: 0]= 1000 One interrupt occurs for every 4.0 seconds
I _{WDT}	WDT Current	-	6.1	7.3	μA	WDTCKS[2: 0]= 000 WDT overflows every 500ms
I _{TK1}	TouchKey operating current (High Sensitivity Mode)	-	1.3	1.7	mA	
I _{TK2}	TouchKey operating current (High Reliability Mode)	-	0.4	0.6	mA	
I/O Port Features						
V _{IH1}	Input high voltage	0.7V _{DD}	-	V _{DD} +0.3	V	
V _{IL1}	Input low voltage	-0.3	-	0.3V _{DD}	V	
V _{IH2}	Input high voltage	0.8V _{DD}	-	V _{DD}	V	Schmidt trigger input:
V _{IL2}	Input low voltage	-0.2	-	0.2V _{DD}	V	RST/tCK/SCK

IO _{L1}	Output low current	-	40	-	mA	V _{Pin} =0.4V
IO _{L2}	Output low current	-	70	-	mA	V _{Pin} =0.8V
IO _{H1}	Output high current P1/P5	-	20	-	mA	V _{Pin} =4.3V
IO _{H2}	Output high current P1/P5	-	10	-	mA	V _{Pin} =4.7V
IO _{H3}	Output high current P0/P2	-	20	-	mA	V _{Pin} =4.3V P _{xyz} = 0, IO _H level 0
	Output high current P0/P2	-	9.8	-	mA	V _{Pin} =4.3V P _{xyz} = 1, IO _H level 1
	Output high current P0/P2	-	5.0	-	mA	V _{Pin} =4.3V P _{xyz} = 2, IO _H level 2
	Output high current P0/P20 ~ P23	-	1.8	-	mA	V _{Pin} =4.3V P _{xyz} = 3, IO _H level 3
	Output high current P24 ~ P27	-	2.6	-	mA	V _{Pin} =4.3V P _{xyz} = 3, IO _H level 3
IO _{H4}	Output high current P0/P2	-	9.6	-	mA	V _{Pin} =4.7V P _{xyz} = 0, IO _H level 0
	Output high current P0/P2	-	4.4	-	mA	V _{Pin} =4.7V P _{xyz} = 1, IO _H level 1

	Output high current P0/P2	-	2.3	-	mA	$V_{Pin}=4.7V$ $P_{xyz} = 2, I_{OH}$ level 2
	Output high current P0/P20 ~ P23	-	0.8	-	mA	$V_{Pin}=4.7V$ $P_{xyz} = 3, I_{OH}$ level 3
	Output high current P24 ~ P27	-	1.2	-	mA	$V_{Pin}=4.7V$ $P_{xyz} = 3, I_{OH}$ level 3
R_{PH1}	Pull-up resistance	-	33	-	k Ω	
Internal calibrated 2.4V as ADC reference voltage						
V_{DD24}	Internal reference 2.4V voltage output	2.38	2.40	2.42	V	$T_A=-40 \sim 85^\circ C$

($V_{DD} = 3.3V$, $T_A = +25^\circ C$, unless otherwise specified)

Symbol	Parameter	Min Value	Typical Value	Max Value	Unit	Conditions
Current						
I_{op4}	Operating current	-	5.8	-	mA	$f_{SYS} = 12MHz$
I_{op5}	Operating current	-	4.8	-	mA	$f_{SYS} = 6MHz$
I_{op6}	Operating current	-	4.2	-	mA	$f_{SYS} = 2MHz$
I_{pd2}	Standby Current (Power Down Mode)	-	0.7	1.0	μA	
I_{IDL2}	Standby Current (IDLE Mode)	-	5.9	-	mA	

I _{TK3}	TouchKey operating current (High Sensitivity Mode)	-	1.2	1.5	mA	
I _{TK4}	TouchKey operating current (High Reliability Mode)	-	0.3	0.4	mA	
I/O Port Features						
V _{IH3}	Input high voltage	0.7V _{DD}	-	V _{DD} +0.3	V	
V _{IL3}	Input low voltage	-0.3	-	0.3V _{DD}	V	
V _{IH4}	Input high voltage	0.8V _{DD}	-	V _{DD}	V	Schmidt trigger input: RST/tCK/SCK
V _{IL4}	Input low voltage	-0.2	-	0.2V _{DD}	V	
I _{OL3}	Output low current	-	31	-	mA	V _{Pin} =0.4V
I _{OL4}	Output low current	-	55	-	mA	V _{Pin} =0.8V
I _{OH5}	Output high current	-	6	-	mA	V _{Pin} =3.0V
R _{PH2}	Pull-up resistance	-	56	-	kΩ	
Internal calibrated 2.4V as ADC reference voltage						
V _{DD24}	Internal reference 2.4V voltage output	2.38	2.40	2.42	V	T _A =-40 ~ 85°C

22.4 AC Characteristics

($V_{DD} = 2.4V \sim 5.5V$, $T_A = 25^\circ C$, unless otherwise specified)

Symbol	Parameter	Min	Typical	Max	Unit	Conditions
T_{OSC1}	External high-frequency oscillator start-up time	-	9	1	ms	External 16 MHz crystal oscillator
T_{OSC2}	External high-frequency oscillator start-up time	-	18	-	ms	External 8 MHz crystal oscillator
T_{OSC3}	External high-frequency oscillator start-up time	-	35	-	ms	External 4 MHz crystal oscillator
T_{POR}	Power On Reset time	-	1	1.5	ms	
T_{PDW}	Power Down Mode waking-up time	-	1	1.5	ms	
T_{Reset}	Reset Pulse Width	18	-	-	μs	Valid for Low level
f_{HRC}	RC oscillation stability	23.76	24	24.24	MHz	$V_{DD}=3.0 \sim 5.5V$ $T_A=-20 \sim 85^\circ C$

22.5 ADC Characteristics

($T_A = 25^\circ C$, unless otherwise specified)

Symbol	Parameter	Min	Typical	Max	Unit	Conditions
V_{AD}	Supply Voltage	2.4	5.0	5.5	V	
N_R	Precision	-	12	-	bit	$GND \leq V_{AIN} \leq V_{DD}$

V_{AIN}	ADC Input Voltage	GND	-	V_{DD}	V	
R_{AIN}	ADC input resistance	1	-		$M\Omega$	$V_{IN}=5V$
I_{ADC1}	ADC conversion current 1	-	2.7	3.2	mA	ADC Module on $V_{DD}=5V$
I_{ADC2}	ADC conversion current 2	-	2.1	2.5	mA	ADC module on $V_{DD}=3.3V$
DNL	Differential nonlinear error	-	± 1	-	LSB	$V_{DD}=5V$ $V_{REF}=5V$
INL	Integral nonlinear error	-	± 2	-	LSB	
E_Z	Offset error	-	± 10	-	LSB	
E_F	Full scale error	-	0	-	LSB	
E_{AD}	Total absolute error	-	± 10	-	LSB	
T_{ADC1}	ADC conversion time 1	-	10	-	μs	ADC Clock = 2MHz ADC sampling period =6
T_{ADC2}	ADC conversion time 2	-	20	-	μs	ADC Clock = 1MHz ADC sampling period =6

23 Application Circuit

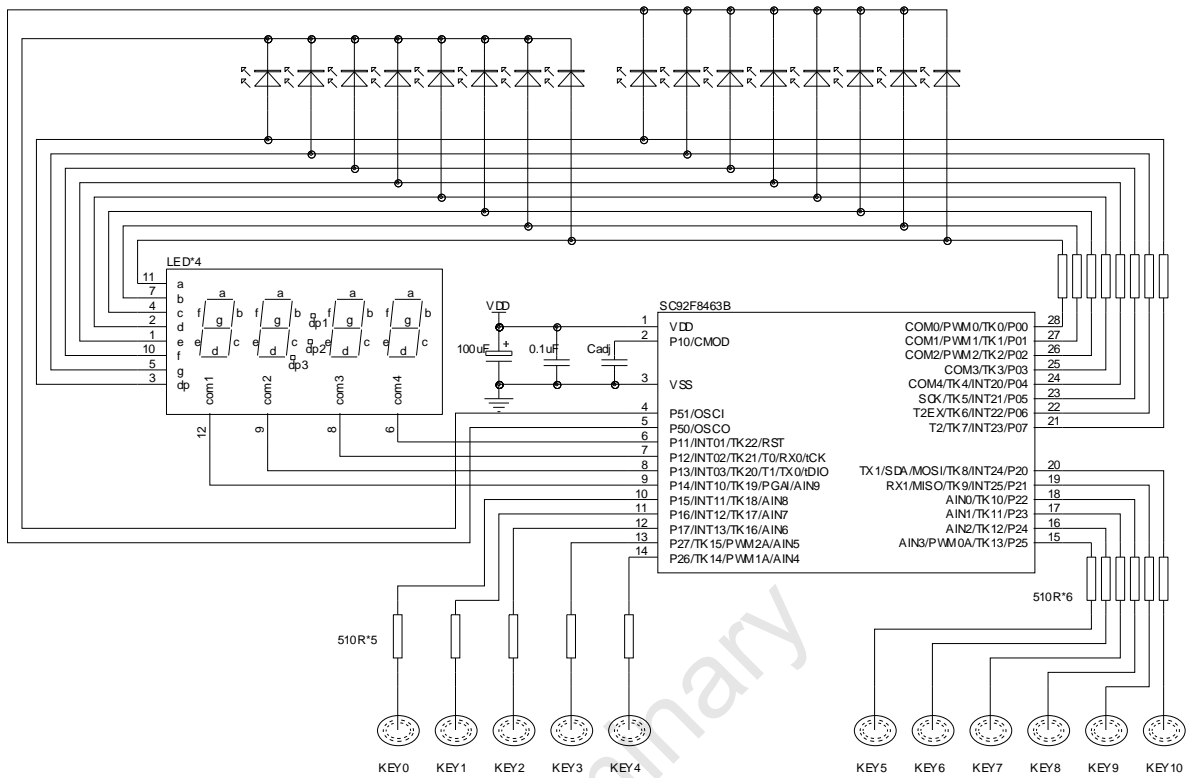

The SC92F8463B TouchKey Application Circuit Diagram

24 Ordering Information

PRODUCT NO	PKG	PACKING
SC92F8463BM28U	SOP28L	TUBE
SC92F8463BX28U	TSSOP28L	TUBE
SC92F8462BM20U	SOP20L	TUBE
SC92F8462BX20U	TSSOP20L	TUBE
SC92F8461BM16U	SOP16L	TUBE

Preliminary

25 Packageing Information

The SC92F8463BM28U

SOP28L (300mil) Dimension

Unit: mm

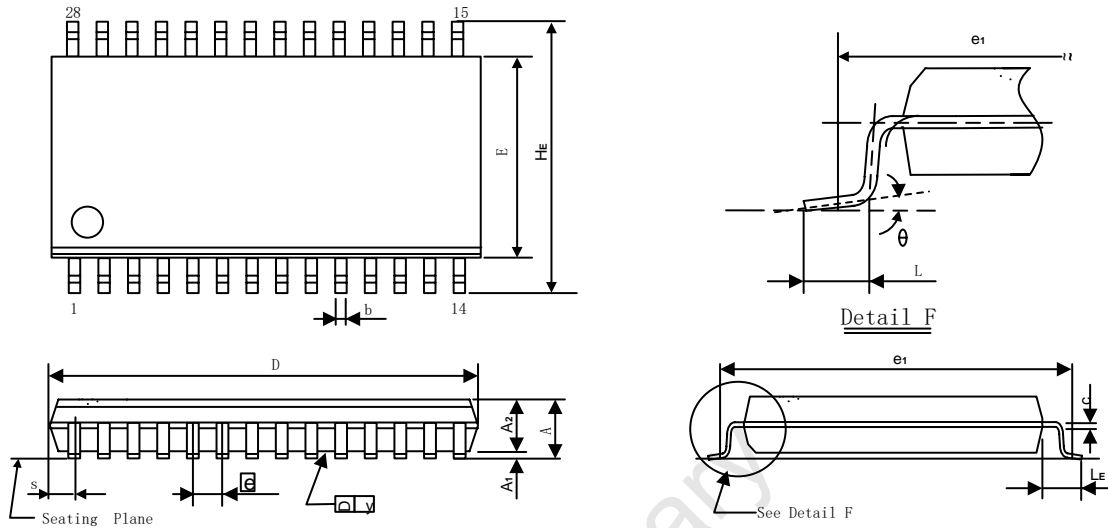

Symbol	mm (millimetre)		
	Min	Normal	Max
A	2.465	2.515	2.565
A1	0.100	0.150	0.200
A2	2.100	2.300	2.500
b	0.356	0.406	0.456
C	0.254 (BSC)		
D	17.750	17.950	18.150
E	7.374	7.450	7.574
HE	10.100	10.300	10.500

e	1.270 (BSC)		
L	0.764	0.864	0.964
LE	1.303	1.403	1.503
θ	0°	-	10°
S	0.745 (BSC)		

Preliminary

The SC92F8463BX28U

TSSOP28 Dimension Unit: mm

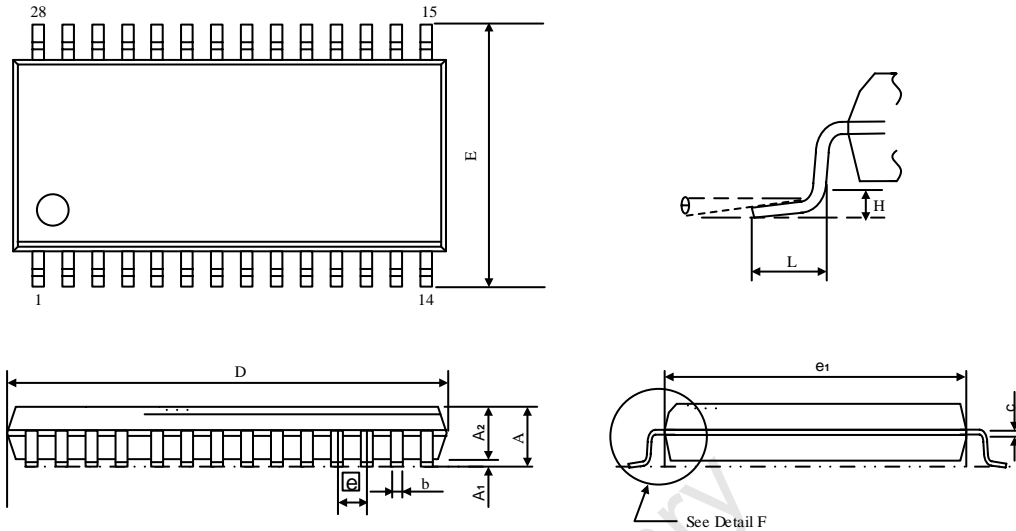

Symbol	mm (milimetre)		
	Min	Normal	Max
A	-	-	1.200
A1	0.050	-	0.150
A2	0.800	-	1.000
b	0.190	-	0.300
c	0.090	-	0.200
D	9.600	-	9.800
E	6.250	-	6.550
e1	4.300	-	4.500

e	0.65 (BSC)		
L	0.500	-	0.700
θ	1°	-	7°
H	0.25 (TYP)		

Preliminary

The SC92F8462BM20U

SOP20L (300mil) Dimension Unit: mm

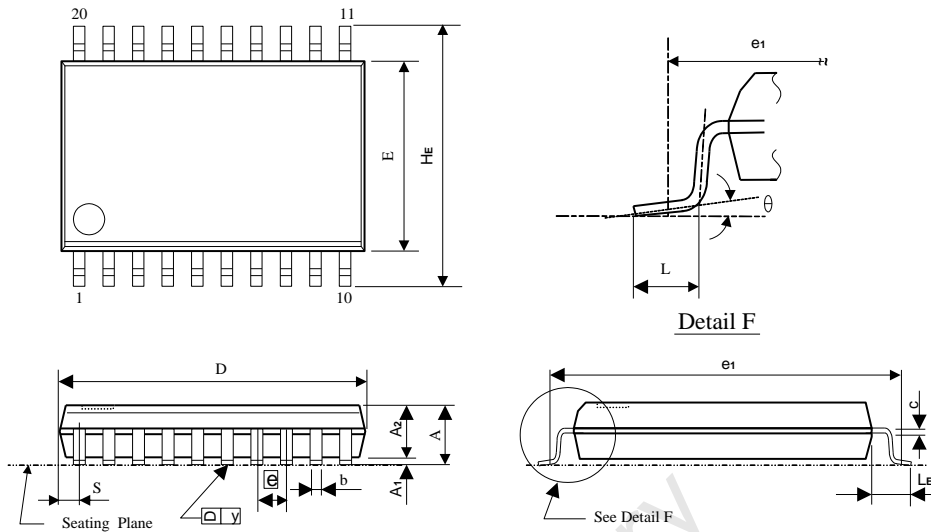

Symbol	mm (millimetre)		
	Min	Normal	Max
A	2.465	2.515	2.565
A1	0.100	0.150	0.200
A2	2.100	2.300	2.500
b	0.356	0.406	0.456
C	0.254 (BSC)		
D	12.500	12.700	12.900
E	7.400	7.450	7.500
HE	10.206	10.306	10.406

e	1.27 (BSC)		
L	0.800	0.864	0.900
LE	1.303	1.403	1.503
θ	0°	-	10°
S	0.660 (BSC)		

Preliminary

SC92F8462BX20U

TSSOP20L Dimension Unit: mm

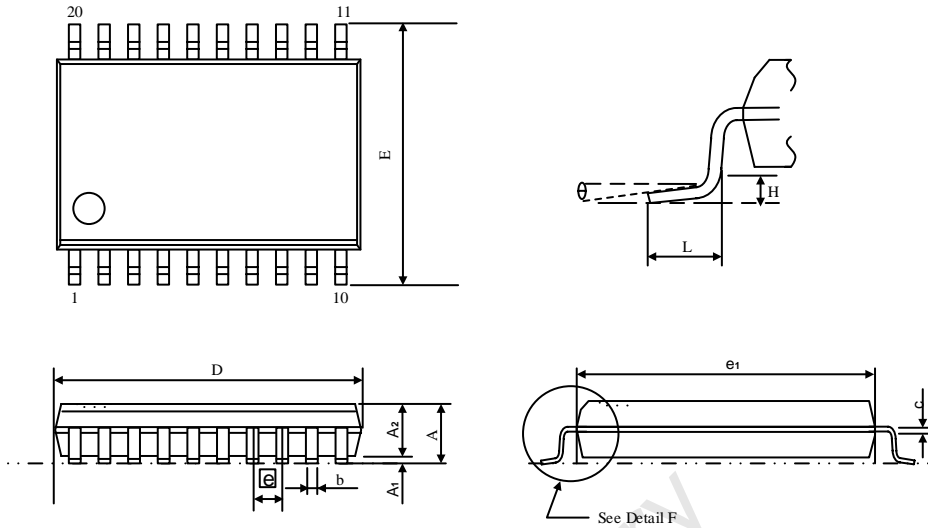

Symbol	mm (milimetre)		
	Min	Normal	Max
A	-	-	1.200
A1	0.050	-	0.150
A2	0.800	-	1.000
b	0.190	-	0.300
c	0.090	-	0.200
D	6.400	-	6.600
E	6.250	-	6.550
e1	4.300	-	4.500

e	0.65 (BSC)		
L	0.500	-	0.700
θ	1°	-	7°
H	0.25 (TYP)		

Preliminary

SC92F8461BM16U

SOP16L (150mil) Dimension Unit: mm

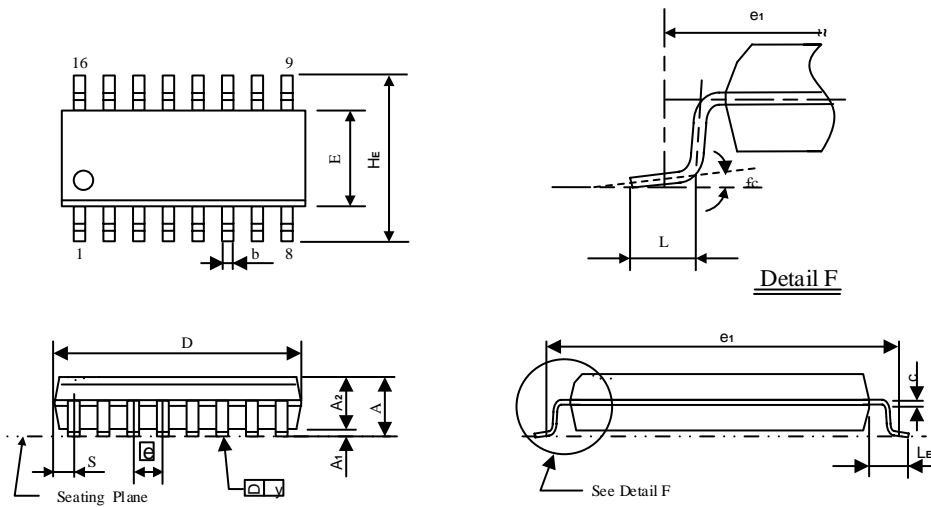

Symbol	mm (milimetre)		
	Min	Normal	Max
A	1.500	1.600	1.700
A1	0.100	0.150	0.200
A2	1.400	1.450	1.500
b	0.356	0.406	0.470
C	0.203 (BSC)		
D	9.700	9.900	10.160
S	0.505 (BSC)		
E	3.800	3.900	4.000
HE	5.900	6.000	6.100

e	1.27 (BSC)		
L	0.500	0.660	0.700
LE	0.950	1.050	1.150
θ	0°	-	8°

Preliminary

26 Revision History

Version	Notes	Date
V0.1	Initial Release.	November 2019

Preliminary